





## MECHANICAL LEGEND AND ABBREVIATIONS

ABBREVIATIONS	GRAPHICAL REFERENCE
ADA	AMERICAN W/DISABILITIES ACT
APPROX.	APPROXIMATE
ARCH	ARCHITECT, ARCHITECTURAL
AVG.	AVERAGE
BHP	BRAKE HORSEPOWER
BMS	BUILDING AUTOMATION SYSTEM
BTU	BRITISH THERMAL UNIT
BTUH	BTU PER HOUR
CFM	CUBIC FEET PER MINUTE
CFOI	CONTRACTOR FURNISHED OWNER INSTALL
CO	CARBON MONOXIDE
CO2	CARBON DIOXIDE
CU.FT.	CUBIC FEET
CU.IN.	CUBIC INCHES
dB	DECIBEL
DB	DRY BULB (AIR)
DDC	DIRECT DIGITAL CONTROL
DEG.	DEGREE
DMPR	DAMPER
DN	DOWN
DPS	DIFFERENTIAL PRESSURE SENSOR
DIWV	DRAIN WASTE AND VENT
EA	EACH
EAT	ENTERING AIR TEMPERATURE
EGT	ENTERING GLYCOL TEMPERATURE
ELEC	ELECTRICAL
ESP	EXTERNAL STATIC PRESSURE
EWT	ENTERING WATER TEMPERATURE
F	FAHRENHEIT
FDC	FIRE DEPARTMENT CONNECTION
FPM	FEET PER MINUTE
FPS	FEET PER SECOND
FU	FIXTURE UNIT
GAL	GALLON
GALV.	GALVANIZED
GPH	GALLON PER HOUR
GPM	GALLON PER MINUTE
HEPA	HIGH EFFICIENCY PARTICULATE ARREST (FILTER)
HP	HORSEPOWER (ELEC.)
HZ	HERTZ (ELEC.)
IAQ	INDOOR AIR QUALITY
IN.W.C.	INCH, WATER COLUMN
KW	KILOWATT
KWH	KILOWATT HOUR
LAT	LEAVING AIR TEMPERATURE
LB	POUND
LGT	LEAVING GLYCOL TEMPERATURE
LWT	LEAVING WATER TEMPERATURE
MAT	MIXED AIR TEMPERATURE
MAX	MAXIMUM
MBH	1,000 BTU PER HOUR
MECH	MECHANICAL
MIN.	MINIMUM
MISC.	MISCELLANEOUS
MMBH	1,000,000 BTU PER HOUR
NC	NORMALLY CLOSED
NIC	NOT IN CONTRACT
NO	NORMALLY OPEN
NTS	NOT TO SCALE
OAT	OUTSIDE AIR TEMPERATURE
OFCI	OWNER FURNISHED CONTRACTOR INSTALL
OFOI	OWNER FURNISHED OWNER INSTALL
PD	PRESSURE DROP
PG	PROPYLENE GLYCOL
PH	PHASE (ELEC)
PRES	PRESSURE
PSI	POUND PER SQUARE INCH
PSIA	PSI ABSOLUTE
PSIG	PSI GAUGE
RH	RELATIVE HUMIDITY
RPM	REVOLUTION PER MINUTE
S	SWITCH (SYMBOLIC)
SEC.	SECOND
SSTL	STAINLESS STEEL
T	THERMOSTAT (SYMBOLIC)
TEMP.	TEMPERATURE
TYP.	TYPICAL
UON	UNLESS OTHERWISE NOTED
V	VOLT (ELEC.)
VEL	VELOCITY
VFD	VARIABLE FREQUENCY DRIVE
W/	WITH
W/O	WITHOUT
WB	WET BULB









ADDITIONAL ABBREVIATIONS NOTED BY EQUIPMENT TAGS, SYSTEM SYMBOLS, AND ACRONYMS GENERALLY ACCEPTED BY THE INDUSTRY SHALL BE APPLICABLE.

## DUCT WORK AND PIPING COLOR LEGEND

### DUCT WORK SYSTEMS:

	SUPPLY AIR DUCT WORK
	RETURN AIR DUCT WORK
	EXHAUST AIR DUCT WORK
	OUTSIDE AIR DUCT WORK

### PIPING SYSTEMS:

	DOMESTIC COLD WATER PIPING
	DOMESTIC HOT WATER PIPING
	DOMESTIC HOT WATER CIRCULATION PIPING
	HYDRONIC SUPPLY PIPING
	HYDRONIC RETURN PIPING
	REFRIGERANT PIPING
	FUEL OIL PIPING
	FUEL GAS PIPING

CERTAIN EQUIPMENT CONNECTIONS MAY VARY. INTERPRET DRAWINGS FOR INTENDED INSTALLATION OR REQUEST CLARIFICATION AS NEEDED.

COLOR VERSION OF THESE DRAWINGS IN ELECTRONIC FORMAT (INCLUDING PDF, JPEG, ETC.) MAY BE AVAILABLE FOR DOWNLOAD FOR PROJECT PERSONNEL UPON REQUEST.

## MECHANICAL DESIGN PARAMETERS

### BUILDING DOMESTIC WATER SYSTEM

TOTAL BUILDING WATER SERVICE LOAD:	78.0 FIXTURE UNITS
BUILDING WATER SERVICE PRESSURE:	OVER 60 PSI
BUILDING WATER SERVICE ENTRANCE:	4 INCH MIN., FIRE SERVICE (FROM UTILITY SERVICE)
DESIGN SYSTEM LENGTH (UPC, TABLE 6-6):	100 FEET

THE SIZING OF THE DOMESTIC WATER PIPING SYSTEM SHALL CONFORM TO UNIFORM PLUMBING CODE, 2012 ED., SECTION 610.8.

PIPE SIZE	FIXTURE UNIT LOAD
1/2"	FIXTURE CONNECTION ONLY
3/4"	20
1"	39
1-1/4"	78
1-1/2"	151
2"	370

### DRAIN, WASTE, AND VENT SYSTEMS

TOTAL BUILDING SEWER SERVICE LOAD:	69 FIXTURE UNITS
BUILDING SEWER SERVICE ENTRANCE:	4 INCH

THE SIZING OF THE BUILDING SANITARY DRAIN, WASTE, AND VENT PIPING SYSTEMS SHALL CONFORM TO UNIFORM PLUMBING CODE, 2012 ED., CHAPTER 7.

### HEATING GENERATION SYSTEMS

DESIGN CONDITION (WINTER/SUMMER):	ASHRAE 99% / 2%, KODIAK AIRPORT, ALASKA
WINTER DESIGN OUTDOOR AMBIENT:	12.9 DEGREES F DRY BULB
SUMMER DESIGN OUTDOOR AMBIENT:	62.4 DEGREES F DRY BULB 54.9 DEGREES F WET BULB

### HYDRONIC PIPING SYSTEMS

MAXIMUM FLUID VELOCITY:	5 FEET PER SECOND
HYDRONIC FLUID:	HOT WATER

UNLESS OTHERWISE NOTED IN DRAWINGS, USE THE FOLLOWING TABLE AS GUIDE TO SELECT PIPING SIZES BASED ON THE FLOW RATE LIMITATIONS.

PIPE SIZE	FLOW RATE LIMITATION (MAX GPM)
3/4"	3.0
1"	6.0
1-1/4"	12.0
1-1/2"	18.0
2"	35.0

### VENTILATION SYSTEMS

DWELLING UNITS: VENTILATION SHALL BE PROVIDED BY EXHAUST VENTILATION SYSTEMS FOR INDIVIDUAL DWELLING UNITS PER INTERNATIONAL MECHANICAL CODE, 2012 ED., TABLE 403.3, AND SECTIONS 403.

#### VENTILATION COMPLIANCE:

BEDROOMS:	15 CFM OUTSIDE AIR
LIVING ROOM/KITCHEN/DINING:	30 CFM OUTSIDE AIR
EXHAUST FAN HIGH/LOW CFM:	50 CFM / 30 CFM

OFFICE WING GENERAL VENTILATION: VENTILATION PROVIDED THROUGH HEAT RECOVERY VENTILATOR WITH CENTRAL RESTROOM EXHAUST SYSTEM.

#### VENTILATION COMPLIANCE:

DESIGN SUPPLY AIR VOLUME:	1160 CFM
OUTSIDE AIR PERCENT:	25%(ROOM OUTSIDE AIR RATIO DESIGN MINIMUM)
ACTUAL OUTSIDE AIR:	400 CFM (FOR EXHAUST OFFSET)
ACTUAL OUTSIDE AIR PERCENT:	35%

GATHERING ROOM VENTILATION: VENTILATION PROVIDED THROUGH OUTSIDE AIR PROVISIONS TO HEAT PUMP SYSTEM INDOOR TERMINAL UNITS.

#### VENTILATION COMPLIANCE:

SPACE AREA:	820 SF
SPACE TYPE (IMC TABLE 403.3):	CONFERENCE ROOM TYPE OCCUPANCY
OCCUPANCY LOAD:	50 OCCUPANTS (EST.)
VENTILATION RATE REQUIRED:	5 CFM/OCC, 0.06 CFM/SF
OUTSIDE AIR REQUIRED:	299 CFM
DESIGN OUTSIDE AIR:	300 CFM

CONFERENCE ROOM VENTILATION: VENTILATION PROVIDED THROUGH OUTSIDE AIR PROVISIONS TO HEAT PUMP SYSTEM INDOOR TERMINAL UNITS.

#### VENTILATION COMPLIANCE:

SPACE AREA:	735 SF
SPACE TYPE (IMC TABLE 403.3):	CONFERENCE ROOM TYPE OCCUPANCY
OCCUPANCY LOAD:	50 OCCUPANTS (EST.)
VENTILATION RATE REQUIRED:	5 CFM/OCC, 0.06 CFM/SF
OUTSIDE AIR REQUIRED:	294 CFM
DESIGN OUTSIDE AIR:	300 CFM

MECHANICAL ROOM: COMBUSTION AIR FOR FUEL-FIRED APPLIANCES PROVIDED THROUGH DEDICATED COMBUSTION AIR INTAKE.

SMALL LOCAL EXHAUST FANS IN INCIDENTAL SPACES PROVIDED TO PREVENT HIGH HUMIDITY LEVEL.

HEAT EXTRACTION FAN PROVIDED FOR TELE/COMM ROOM.

EXHAUST BOOSTER FANS PROVIDED FOR LAUNDRY ROOM CLOTHES DRYERS.

## GENERAL MECHANICAL INFORMATION

### APPLICABLE CODES AND STANDARDS

INTERNATIONAL CODE COUNCIL (ICC) SERIES MODEL CODES, 2012 ED., AS ADOPTED  
INTERNATIONAL ASSOCIATION OF PLUMBING AND MECHANICAL OFFICIALS (IAPMO), UNIFORM PLUMBING CODE (UPC), 2012 ED.

### DEFERRED SUBMITTALS

- SEISMIC/WIND RESTRAINT DESIGN FOR MAJOR EQUIPMENT INSTALLATION:

THE CONTRACTOR SHALL BE RESPONSIBLE FOR THE DEFERRED SUBMITTAL OF THE SEISMIC AND WIND LOAD DESIGN DRAWINGS AND CALCULATIONS PREPARED BY A LICENSED STRUCTURAL ENGINEER FOR APPROVAL FOR MAJOR EQUIPMENT INCLUDING.

- HEATING AND VENTILATION UNIT, HRV-1
- WATER HEATERS (SEISMIC RESTRAINTS)
- BOILERS (ANCHORAGE)
- FUEL OIL TANK (ANCHORAGE)
- PROPANE TANK (SEISMIC RESTRAINTS)

NOTES: DETERMINATION OF COMPONENT IMPORTANCE FACTOR FOR MECHANICAL AND ELECTRICAL COMPONENTS: REFERENCE ASCE STANDARD 7, CHAPTER 13 FOR APPLICABLE DESIGN REQUIREMENTS EXCEPT, UNLESS OTHERWISE DETERMINED, COMPONENT IMPORTANCE FACTOR OF 1.5 SHALL BE USED IN ALL DESIGN SEISMIC FORCE CALCULATIONS.

- SPRINKLER SYSTEMS:

THE CONTRACTOR SHALL BE RESPONSIBLE FOR THE DESIGN AND PERMITTING OF THE FIRE PROTECTION SPRINKLER SYSTEMS. THE SPRINKLER SYSTEMS SHALL BE DESIGNED AND CERTIFIED BY PERSON(S) HOLDING CURRENT NICET IV CERTIFICATIONS.



REV NO: XX DATE



SAJU ARCHITECTURE, LLC

6375 KULIS DRIVE, ANCHORAGE, ALASKA 99502  
#907-440-6606 #907-258-6606 (FAX)



SCOTT A. JONES

OUZINKIE OFFICE  
OUZINKIE NATIVE CORP

JTC  
DR: JTC/TLT  
CK: -  
DT: -  
JB: OUZINKIE  
DWG: GENERAL MECHANICAL NOTES

M1.0

### PLUMBING FIXTURE SCHEDULE

EQ. ID	DESCRIPTION	SERVICE CONNECTIONS				BASIS OF DESIGN: PRIMARY FIXTURE		BASIS OF DESIGN: SECONDARY FIXTURE		COMMENT(S)
		CW	HW	W	V	MANUFACTURER	MODEL	MANUFACTURER	MODEL	
P-1	WATER CLOSET	1/2"		3"	2"					WITH OPEN-FRONT SEAT, LESS LID
P-1A	WATER CLOSET, ADA COMPLIANT	1/2"		3"	2"					WITH OPEN-FRONT SEAT, LESS LID
P-1R	WATER CLOSET, RESIDENT UNITS	1/2"		3"	2"					WITH CLOSED-FRONT SEAT AND LID
P-2	URINAL	3/4"		2"	2"					WITH SLOAN FLUSH VALVE (186 SERIES)
P-3	LAVATORY	1/2"	1/2"	2"	1-1/2"					WITH ASSE A1070 COMPLIANT FAUCET
P-3A	LAVATORY	1/2"	1/2"	2"	1-1/2"					WITH ASSE A1070 COMPLIANT FAUCET
P-3R	LAVATORY, RESIDENT UNITS	1/2"	1/2"	2"	1-1/2"					WITH ASSE A1070 COMPLIANT FAUCET
P-4	BAR SINK, SINGLE-COMPARTMENT	1/2"	1/2"	2"	1-1/2"					WITH ASSE A1070 COMPLIANT FAUCET
P-4R	KITCHEN SINK, DOUBLE-COMPARTMENT, RESIDENT UNITS	1/2"	1/2"	2"	1-1/2"					WITH ASSE A1070 COMPLIANT FAUCET
P-5R	TUB/SHOWER, RESIDENT UNITS	1/2"	1/2"	2"	2"					WITH PRESSURE-BALANCED SHOWER VALVE
P-6	LAVATORY	1/2"	1/2"	2"	1-1/2"					WITH ASSE A1070 COMPLIANT FAUCET
P-7	CLOTHES WASHER OUTLET BOX	1/2"	1/2"	2"	2"					WITH WATER HAMMER ARRESTORS
P-8	JANITOR'S SINK	1/2"	1/2"	2"	2"					
P-9	LAUNDRY TUB	1/2"	1/2"	2"	2"					
P-10	3-COMPARTMENT SINK, WARMING KITCHEN	3/4"	3/4"	2"	2"					

### MISCELLANEOUS PLUMBING EQUIPMENT SCHEDULE

EQ. ID	DESCRIPTION	CONNECTIONS					BASIS OF DESIGN			COMMENTS
		CW	HW	W	V	RL	MANUFACTURER	MODEL	MODEL	
GI-1	GREASE INTERCEPTOR, RATED FOR 15 GPM FLOW, WITH FLOW CONTROL VALVE						JR SMITH	8015		
TP-1	TRAP PRIMER	1/2"					PRECISION PLUMBING PRODUCTS	P1-500		
FD-1	FLOOR DRAIN			2"	2"					
FS-1	FLOOR SINK			2"	2"					

### WATER HEATER SCHEDULE

EQ. ID	DESCRIPTION	FUEL INPUT		TEMP.		TANK SIZE (GAL)	PERFORMANCE		ELECTRICAL				BASIS OF DESIGN		COMMENT(S)
		FUEL TYPE	MBH	GPH	EWT		LWT	1ST HR (GAL)	CONTI. (GPH)	W/KW	AMPS	VOLTAGE	PHASE	MANUFACTURER	
WH-1	STORAGE TANK INDIRECT WATER HEATER	INDIRECT	91		50 °F	115 °F	80	270						HTP	CONTENDER SERIES, SSC-80
WH-2	STORAGE TANK INDIRECT WATER HEATER	INDIRECT	91		50 °F	115 °F	80	270						HTP	CONTENDER SERIES, SSC-80

### BOILER SCHEDULE

EQ. ID	DESCRIPTION	PERFORMANCE				ELECTRICAL				BASIS OF DESIGN		COMMENT(S)
		FUEL TYPE	INPUT (MBH)	INPUT (GPH)	OUTPUT (MBH)	W/KW	AMPS	VOLTAGE	PHASE	MANUFACTURER	MODEL	
BLR-1	OIL-FIRED CAST IRON SECTIONAL BOILER	FUEL OIL	203	1.45	152	15	120	1	WEIL MCLAIN	WGO-5		
BLR-2	OIL-FIRED CAST IRON SECTIONAL BOILER	FUEL OIL	203	1.45	152	15	120	1	WEIL MCLAIN	WGO-5		

### PUMP SCHEDULE

EQ. ID	DESCRIPTION	FLUID TYPE	PERFORMANCE		PUMP INFORMATION		VFD (YES/NO)	MOTOR		ELECTRICAL			BASIS OF DESIGN		COMMENT(S)	
			FLOW	HEAD	SIZE	IMPELLER		HP	RPM	W/KW	AMPS	VOLT	PHASE	MANUFACTURER		MODEL
CP-1A	PRIMARY HYDRONIC PUMP	PG 50	31.40 GPM	35.0 FT			YES			800	115	1	TACO	VIRIDIAN VR20		
CP-1B	PRIMARY HYDRONIC PUMP	PG 50	31.40 GPM	35.0 FT			YES			800	115	1	TACO	VIRIDIAN VR20		
CP-21	BOILER CIRCULATION PUMP	PG 50	15.60 GPM	10.0 FT			NO	1/6			120	1	TACO	0013		
CP-22	BOILER CIRCULATION PUMP	PG 50	15.60 GPM	10.0 FT			NO	1/6			120	1	TACO	0013		
CP-31	WATER HEATER HEATING CIRCULATION PUMP	PG 50	12.00 GPM	10.0 FT			NO	1/6			120	1	TACO	0013		
CP-32	WATER HEATER HEATING CIRCULATION PUMP	PG 50	12.00 GPM	10.0 FT			NO	1/6			120	1	TACO	0013		
CP-41	DOMESTIC HOT WATER CIRCULATION PUMP	DHW	2.00 GPM	15.0 FT			NO						TACO	008		
GT-1	GLYCOL MAKE-UP TANK PACKAGE	PG 50								50	120	1	AXIOM INDUSTRY	MF-200	WITH LOW LEVEL ALARM MODULE. COORDINATE FOR DUPLEX ELECTRICAL OUTLET ADJACENT TO UNIT.	
RMB-1	RADIANT FLOOR SYSTEM ZONE PUMP	PG 50									2.0	120	1	TACO	RMB-1	SEE RADIANT SYSTEM SCHEDULE FOR ADDITIONAL INFORMATION
RMB-2	RADIANT FLOOR SYSTEM ZONE PUMP	PG 50									2.0	120	1	TACO	RMB-1	SEE RADIANT SYSTEM SCHEDULE FOR ADDITIONAL INFORMATION
RMB-3	RADIANT FLOOR SYSTEM ZONE PUMP	PG 50									2.0	120	1	TACO	RMB-1	SEE RADIANT SYSTEM SCHEDULE FOR ADDITIONAL INFORMATION
RMB-4	RADIANT FLOOR SYSTEM ZONE PUMP	PG 50									2.0	120	1	TACO	RMB-1	SEE RADIANT SYSTEM SCHEDULE FOR ADDITIONAL INFORMATION

### HYDRONIC TERMINAL UNIT SCHEDULE

EQ. ID	DESCRIPTION	OUTPUT (MBH)	AIRFLOW (CFM)	HYDRONIC				MOTOR			W/KW	AMP	VOLT	PHASE	BASIS OF DESIGN		COMMENT(S)
				FLUID TYPE	FLOW (GPM)	PRES. (W.C.)	EFT	LFT	HP	RPM					MANUFACTURER	MODEL	
UH-1	HYDRONIC UNIT HEATER	7.1	340 CFM	PG 50	0.80 GPM	0.50 FT	180 °F	160 °F	1/60				120	1	MODINE	HC-18	

### HEATING AND COOLING COIL SCHEDULE

EQ. ID	DESCRIPTION	CAP (MBH)	FLOW (CFM)	SP (IN WC)	EAT	LAT	FLUID TYPE	FLOW (GPM)	PD (FT WC)	EFT	LFT	BASIS OF DESIGN		COMMENT(S)
												MANUFACTURER	MODEL	
HC-1	REHEAT COIL	32.4	1150	0.08	42 °F	68 °F	PG 50	3.6	2.5	180 °F	160 °F	GREENHECK	HW58S01B12-20X10	20"X10" COIL DIMENSIONS

### HEAT PUMP OUTDOOR UNIT SCHEDULE

EQ. ID	DESCRIPTION	PERFORMANCE (RATED)				REFRIGERANT		ELECTRICAL			BASIS OF DESIGN		COMMENT
		CLG CAP (MBH)	CLG SEER/IEER	HTG CAP (MBH)	HTG COP	TYPE	CHARGE (LB)	VOLTAGE	PHASE	MCA/MOP (AMP)	MANUFACTURER	MODEL	
ACCU-1	HEAT PUMP OUTDOOR UNIT	57.0		57.0				240	1	29/35	DAIKIN	RXTQ60TAVJU	
ACCU-2	HEAT PUMP OUTDOOR UNIT	57.0		57.0				240	1	29/35	DAIKIN	RXTQ60TAVJU	

### HEAT PUMP INDOOR UNIT SCHEDULE

EQ. ID	DESCRIPTION	PERFORMANCE (RATED)				REFRIGERANT	ELECTRICAL			BASIS OF DESIGN		COMMENT
		CLG CAP (MBH)	HTG CAP (MBH)	CLG LOAD (KW)	HTG LOAD (KW)		TYPE	VOLTAGE	PHASE	MCA/MOP (AMP)	MANUFACTURER	
FCU-11	CEILING RECESSED CASSETTE FAN COIL UNIT	9.5	11.1				240	1	0.8/15	DAIKIN	FXZQ09	
FCU-12	CEILING RECESSED CASSETTE FAN COIL UNIT	9.5	11.1				240	1	0.8/15	DAIKIN	FXZQ09	
FCU-13	CEILING RECESSED CASSETTE FAN COIL UNIT	9.5	11.1				240	1	0.8/15	DAIKIN	FXZQ09	
FCU-21	CEILING RECESSED CASSETTE FAN COIL UNIT	9.5	11.1				240	1	0.8/15	DAIKIN	FXZQ09	
FCU-22	CEILING RECESSED CASSETTE FAN COIL UNIT	9.5	11.1				240	1	0.8/15	DAIKIN	FXZQ09	
FCU-23	CEILING RECESSED CASSETTE FAN COIL UNIT	9.5	11.1				240	1	0.8/15	DAIKIN	FXZQ09	

### INSULATION SCHEDULE

#### DUCT WORK INSULATION REQUIREMENTS:

SUPPLY AIR DUCT: NONE  
 RETURN AIR DUCT: NONE  
 OUTSIDE AIR DUCT: 2" INSULATION WITH VAPOR BARRIER  
 EXHAUST AIR DUCT (CONDITIONED SPACES): 1" INSULATION WITH VAPOR BARRIER WITHIN 5 FEET OF EXTERIOR WALL  
 EXHAUST AIR DUCT (ATTIC): 1" INSULATION WITH VAPOR BARRIER  
 EXHAUST DUCT (WARMING KITCHEN HOOD): NONE

#### PIPING INSULATION REQUIREMENTS:

DOMESTIC COLD WATER: NONE  
 DOMESTIC HOT WATER: 1" INSULATION WITH ALL PURPOSE JACKET  
 DOMESTIC HOT WATER CIRCULATION: 1" INSULATION WITH ALL PURPOSE JACKET  
 SANITARY WASTE PIPING: NONE  
 HYDRONIC HEATING PIPING SYSTEM: 1" INSULATION WITH ALL PURPOSE JACKET  
 REFRIGERANT LINE, LIQUID AND SUCTION: 1" CLOSED-CELL FOAM INSULATION  
 CONDENSATE DRAIN: NONE  
 RADIANT SYSTEM LOOP RUNOUT/TAILOUT: 1" CLOSED-CELL FOAM INSULATION



REV NO: XX DATE



SAJU ARCHITECTURE, LLC

6375 KULIS DRIVE, ANCHORAGE, ALASKA 99502  
 #907-440-6606 #907-258-6606 (FAX)

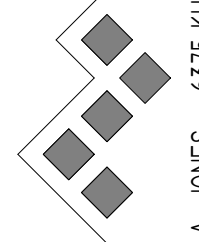

OUZINKIE OFFICE  
 OUZINKIE NATIVE CORP

DR: JTC  
 CK: JTC/TLT  
 DT: -  
 JB: OUZINKIE  
 DWG: MECHANICAL EQUIPMENT SCHEDULES

M1.1

### FAN SCHEDULE

EQ. ID	DESCRIPTION	PERFORMANCE		FAN INFORMATION		VFD (YES/NO)	MOTOR		ELECTRICAL			BASIS OF DESIGN		COMMENT(S)	
		CFM	ESP (in-wc)	DRIVE	RPM		HP	RPM	W/KW	AMPS	VOLTAGE	PHASE	MANUFACTURER		MODEL
CEF-1	CRAWL SPACE VENTILATION FAN	100	0.25							120	1	FANTECH	FR 100	WITH ON/OFF CONTROL BY DEDICATED CRAWL SPACE HUMIDISTAT	
EF-1	EXHAUST FAN, RESTROOMS	100	0.25							0.27	120	1	PANASONIC	WHISPERGREEN SELECT FV-05-11VKS1	AUTOMATIC HIGH-LOW FAN CFM CONTROL WITH OCCUPANCY SENSOR.
EF-1R	EXHAUST FAN, RESIDENT UNITS	50	0.25							0.27	120	1	PANASONIC	WHISPERGREEN SELECT FV-05-11VKS1	HIGH-LOW FAN CFM CONTROL WITH WALL SWITCH (COORDINATE WITH ELECTRICAL) AND WITH HUMIDITY SENSOR FOR HIGH HUMIDITY LEVEL OVERRIDE TO HIGH CFM.
EF-2	EXHAUST FAN, KITCHEN	200	0.25							42W	120	1	PANASONIC	WHISPERCEILING FV-20VQ3	
EF-3	PANTRY/STORAGE	50	0.25							0.27	120	1	PANASONIC	WHISPERGREEN SELECT FV-05-11VKS1	HIGH-LOW FAN CFM CONTROL WITH HUMIDITY SENSOR FOR HIGH HUMIDITY LEVEL OVERRIDE TO HIGH CFM.
EF-4	LAUNDRY ROOM	50	0.25							0.27	120	1	PANASONIC	WHISPERGREEN SELECT FV-05-11VKS1	HIGH-LOW FAN CFM CONTROL WITH HUMIDITY SENSOR FOR HIGH HUMIDITY LEVEL OVERRIDE TO HIGH CFM.
EF-5	CENTRAL EXHAUST FAN, INLINE	350	0.00							1.10	120	1	PANASONIC	WHISPERLINE FV-40IFL	
EF-6	LAUNDRY DRYER BOOSTER FANS	200								0.54	120	1	FANTECH	DBF 110	
EF-7	TRANSFER FAN / IT ROOM	100	0.10							0.23	120	1	PANASONIC	WHISPERCEILING FV-15VQ5	
HD-1	KITCHEN HOOD	500	0.00								120	1	GREENHECK	GRRS-36	
HD-1R	KITCHEN EXHAUST HOOD, RESIDENT UNITS	200								2.0	120	1	NUTONE	RL6200 SERIES OR EQUAL	INTERLOCK WITH KEF-1
HRV-1	HEAT RECOVERY VENTILATOR	1160	0.60							18.8	120	1	LIFEBREATH	1200 FD	
KEF-1	KITCHEN HOOD EXHAUST FAN	500								2.10	120	1	FANTECH	FG 12 EC	

### AIR TERMINAL SCHEDULE

EQ. ID	DESCRIPTION	TERMINAL TYPE		NUM. OF SLOTS	SLOT SIZE	PERFORMANCE			BASIS OF DESIGN		COMMENT(S)	
		FACE SIZE	NECK SIZE			AIRFLOW (CFM)	TSP (IN. W.C.)	NOISE	MANUFACTURER	MODEL		
LV-1												
SA-1	SQUARE PLAQUE DIFFUSER WITH CEILING GRID PANEL	12"X12" (24"X24" GRID PANEL)	6"						PRICE		SPD SERIES	
SA-2	SQUARE PLAQUE DIFFUSER WITH CEILING GRID PANEL	12"X12" (24"X24" GRID PANEL)	8"						PRICE		SPD SERIES	
SA-3	SIDEWALL NOZZLES, DUAL NOZZLE WITH FRAME	24"X12"	8"(X2)						PRICE		AND SERIES DUPLEX WITH WALL PLATE	
SA-4	SQUARE PLAQUE DIFFUSER	12"X12"	6"						PRICE		SPD SERIES	
SA-5	LINEAR SLOT DIFFUSER	48"	8"						PRICE		TBD2 (2 SLOTS)	
RA-1	RETURN AIR DIFFUSER, EGG CRATE CORE	12"X12"	6"						PRICE		80 SERIES	
RA-2	LINEAR SLOT DIFFUSER	48"	8"						PRICE		TBD2 (2 SLOTS)	
RA-3	RETURN AIR DIFFUSER	16"	12"						PRICE		REG-RR SERIES	
EA-1	EXHAUST AIR DIFFUSER	8"X8"	5"						PRICE		80 SERIES	
EA-2	EXHAUST AIR DIFFUSER	12"X12"	8"						PRICE		80 SERIES	
EA-3	KHD-1 EXHAUST OUTLET		12"						SEIHO		SFX SERIES	REMOVE INTERNAL GRILLE, PROVIDE BACKDRAFT DAMPER AT DIFFUSER
EA-4	CLOTHES DRYER OUTLET WITH BACKDRAFT DAMPER		4"						SEIHO		SFB SERIES	
EA-5	GENERAL EXHAUST OUTLET WITH BACKDRAFT DAMPER		6"						SEIHO		SFB SERIES	
EA-6	GENERAL EXHAUST OUTLET		10"						SEIHO		SFX SERIES	REMOVE INTERNAL GRILLE, PROVIDE BACKDRAFT DAMPER AT DIFFUSER
TA-1	WALL TRANSFER GRILLE / IT ROOM	12"X6"							PRICE		80 SERIES	
TA-2	WALL TRANSFER GRILLE / IT ROOM	12"X6"							PRICE		80 SERIES	
OA-1	OUTSIDE AIR (INTERIOR), RESIDENT UNIT VENTILATION		4"						SEIHO		TT SERIES	WITH ADJUSTABLE CORE FOR BALANCING
OA-2	OUTSIDE AIR (EXTERIOR), RESIDENT UNIT VENTILATION		4"						PRICE		80 SERIES	
OA-3	OUTSIDE AIR (EXTERIOR), OFFICE, GATHERING, CONF RM	20"X8"							PRICE		80 SERIES	
LV-1	LOUVER WITH DRAINAGE CHANNELS								RUSKIN		ELF6425DD	PROVIDE BIRD SCREEN ON INTERIOR SIDE OF LOUVER

### MISCELLANEOUS MECHANICAL EQUIPMENT SCHEDULE

EQ. ID	DESCRIPTION	PERFORMANCE/ADDITIONAL INFORMATION	ELECTRICAL				BASIS OF DESIGN 1		COMMENT(S)	
			HP	KW	WATTS	AMPS	VOLTAGE	PHASE		MANUFACTURER
AS-1	HYDRONIC AIR SEPARATOR									
ET-1	EXPANSION TANK, HYDRONIC SYSTEM							AMTROL	MODEL ST-42V	
ET-2	EXPANSION TANK, DOMESTIC HOT WATER SYSTEM							AMTROL	MODEL ST-5	
FOT-1	FUEL OIL STORAGE TANK, 1000-GAL							ANCHORAGE TANK	FIREGUARD SERIES OR EQUAL	
PT-1	PROPANE TANK, 45.6-GAL									
	ELECTRIC HEAT TRACE THAW CABLE			100		120	1	THERMON	RGS SERIES	PROVIDE CONCRETE PAD FOR TANK ANCHORAGE. COORDINATE WITH PROPANE SUPPLIER FOR ADDITIONAL STANDBY TANK(S) AS APPROPRIATE. PROVIDE APPORX. 100 WATTS OF CABLE PER DRAIN PAN AT EACH HEAT PUMP OUTDOOR UNIT SUPPORT STAND. SEE SEQUENCE OF OPERATION FOR ADDITIONAL INFORMATION.

### SEQUENCE OF OPERATIONS

#### HEAT GENERATION SYSTEMS

SYSTEM DELIVERY (BUILDING HYDRONIC LOOP) TEMPERATURE RESET BASED ON OUTDOOR AIR TEMPERATURE AS FOLLOWS,

OUTDOOR TEMPERATURE: SUPPLY GLYCOL TEMPERATURE

ABOVE 65 DEG F	(SYSTEM OFF)
65 DEG F*	120 DEG F
32 DEG F*	180 DEG F
BELOW 32 DEG F	180 DEG F

\*: LINEAR SCHEDULE BETWEEN 65 DEG F AND 32 DEG F OUTDOOR AIR TEMPERATURE

INTERLOCK WITH WATER HEATING SYSTEM FOR PRIORITY SYSTEM SUPPLY TEMPERATURE OVERRIDE FOR DOMESTIC WATER HEATING.

BOILER SYSTEM LEAD-LAG ALTERNATING (PROGRAM FOR WEEKLY SWITCH-OVER).

#### DOMESTIC WATER HEATING SYSTEMS

WATER HEATER CIRCULATION PUMP TO CYCLE TO MAINTAIN WATER HEATER CONTENT TEMPERATURE SETPOINT: 120 DEG F.

HOT WATER RECIRCULATION SYSTEM PUMP TO RUN CONTINUOUSLY.

#### HYDRONIC SYSTEMS

PROVIDE PROGRAMMABLE ALTERNATING (WEEKLY) CONTROL OF HYDRONIC SYSTEM MAIN CIRCULATORS.

BOILER CIRCULATION PUMPS SHALL OPERATE FROM BOILER INTEGRAL CONTROLS.

#### RADIANT HEATING SYSTEMS

RADIANT MIXING BLOCKS (RMB) TO OPERATE ON SUBZONE CALL FOR HEAT AND MODULATE INJECTION TO MAINTAIN RADIANT SYSTEM SUPPLY TEMPERATURE (SEE RADIANT SYSTEM ZONE INFORMATION).

INDIVIDUAL SUBZONE THERMOSTAT SHALL CYCLE MANIFOLD MOUNTED CONTROL VALVE(S) TO MAINTAIN SPACE TEMPERATURE SETPOINT: 68 DEG F.

#### OFFICE AREA VENTILATION SYSTEMS, HRV-1/EF-5/HC-1

OFFICE AREA VENTILATION SYSTEMS, HRV-1 AND EF-5, SHALL OPERATE ON SCHEDULE DURING NORMAL BUSINESS HOUR.

HEAT COIL, HC-1, CONTROLS SHALL MODULATE HYDRONIC FLOW TO MAINTAIN LEAVING AIR TEMPERATURE OF 68 DEG F.

PROVIDE OVERRIDE SWITCH IN LOBBY RECEPTION AREA TO OPERATE SYSTEM (1-HOUR DURATION FOR EACH ACTIVATION) DURING OFF HOURS.

#### TYPICAL RESTROOM GENERAL EXHAUST FANS, EF-1

EXHAUST FAN SHALL OPERATE IN HI-LO MODE ON INTEGRAL OCCUPANCY SENSOR.

#### TYPICAL AREA EXHAUST FANS, EF-2/EF-3/EF-4

EXHAUST FAN SHALL OPERATE ON LOCAL ON-OFF SWITCH.

#### CLOTHES DRYER EXHAUST BOOSTER FAN, EF-6

INTERLOCK CLOTHES DRYER EXHAUST BOOSTER FANS WITH CLOTHES DRYERS.

#### IT ROOM HEAT TRANSFER FAN, EF-7

IT ROOM HEAT TRANSFER FAN TO OPERATE ON THERMOSTAT TO MAINTAIN SETPOINT: 85 DEG F.

#### WARMING KITCHEN HOOD EXHAUST FAN, HD-1/KEF-1

EXHAUST FAN KEF-1 TO OPERATE FROM EXHAUST HOOD ON/OFF CONTROL.

#### RESIDENT UNIT EXHAUST FANS, EF-1R

EXHAUST FAN SHALL OPERATE IN HI-LO-OFF MODE ON LOCAL HI-LO-OFF SWITCH.

#### RESIDENT UNIT EXHAUST HOODS, HD-1R

EXHAUST HOOD TO OPERATE ON UNIT ON-OFF SWITCH.

#### HEAT PUMP SYSTEMS

PROVIDE AUTOMATIC CONTROLS TO OPERATE

- INDOOR FAN COIL UNITS TO OPERATE CONTINUOUSLY AND CYCLE COOLING FUNCTIONS TO MAINTAIN ROOM TEMPERATURE SETPOINT: 70 DEG F.
- OUTDOOR UNIT DEFROST DRAIN PAN THAWING CABLE WHEN OUTDOOR TEMPERATURE IS BELOW 32 DEG F.
- LOCKOUT HEAT PUMP OUTDOOR UNITS WHEN OUTDOOR TEMPERATURE IS BELOW 10 DEG F. (ALLOW INDOOR UNITS TO OPERATE).

#### CRAWL SPACE VENTILATION

CRAWL SPACE HUMIDISTAT SHALL CYCLE CRAWL SPACE VENTILATION FANS TO MAINTAIN CRAWL SPACE HUMIDITY LEVEL AT 60% OR BELOW.



REV NO: XX DATE



SAJU ARCHITECTURE, LLC

SCOTT A. JONES 6375 KULIS DRIVE, ANCHORAGE, ALASKA 99502  
#907-440-6606 #907-258-6606 (FAX)

OUZINKIE OFFICE  
OUZINKIE NATIVE CORP

JTC  
DR: JTC/ILT  
CK: -  
DT: -  
JB: OUZINKIE  
DWG: MECHANICAL EQUIPMENT SCHEDULES

M1.2





REV NO: XX DATE

**ingroup** Engineers, Inc.  
 1000 Commercial Park, Suite 200, Anchorage, Alaska 99503  
 (907) 562-1111 FAX (907) 562-1112  
 State of Alaska License No. ME-8423

**SAJJ ARCHITECTURE, LLC**  
 SCOTT A. JONES 6375 KULIS DRIVE - ANCHORAGE, ALASKA 99502  
 #907-440-6606 #907-258-6606 (FAX)

**OUZINKIE OFFICE**  
 OUZINKIE NATIVE CORP

DR: JTC  
 CK: JTC/TLT  
 DT: -  
 JB: OUZINKIE  
 DWG: MECHANICAL PLAN - UNDERFLOOR

**M2.0**

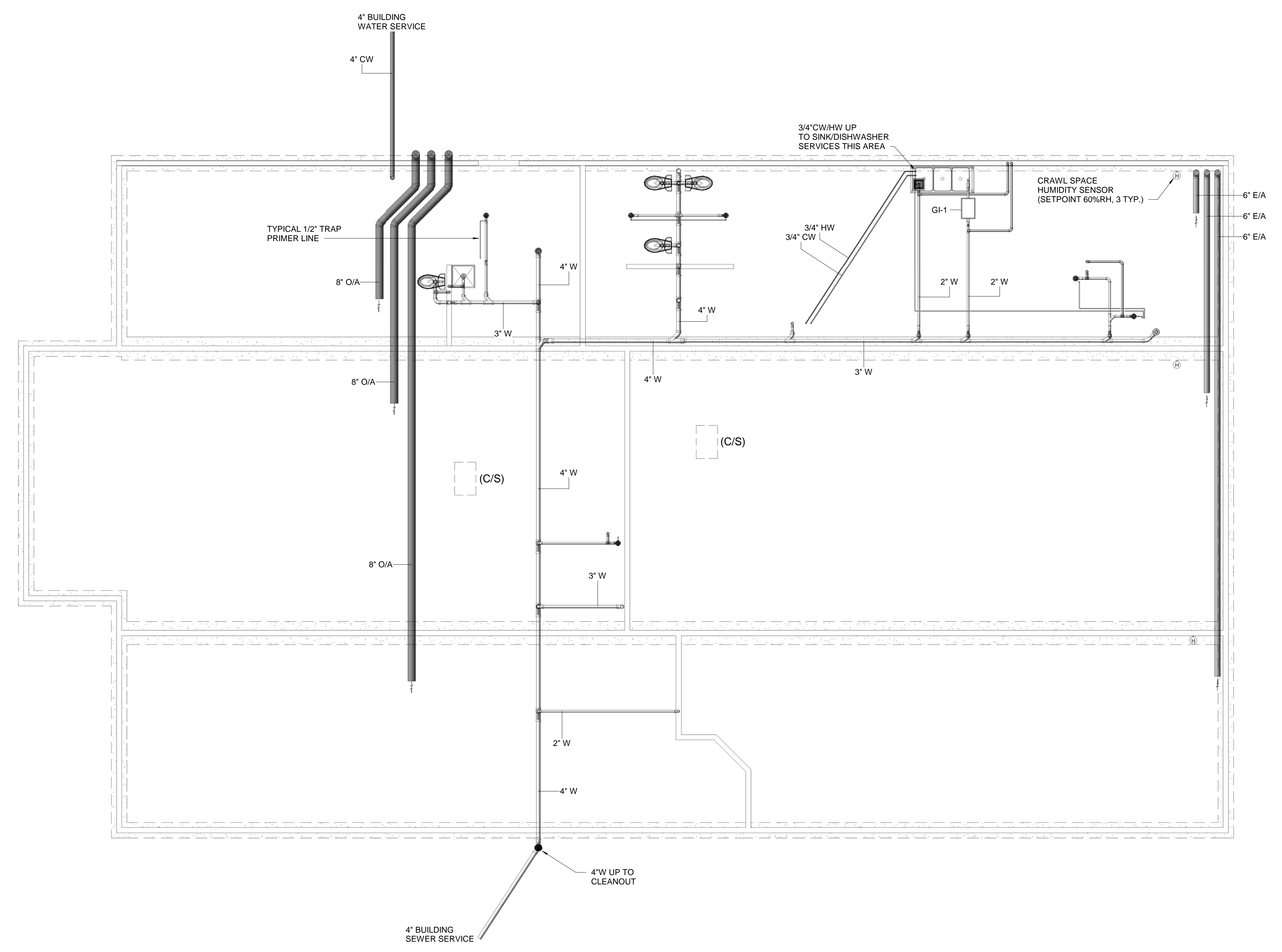

**1 MECHANICAL PLAN - UNDERFLOOR**  
 Scale: 3/16" = 1'-0"

"IIXI7 DRAWINGS ARE HALF THE INDICATED SCALE"



REV NO: XX DATE



SAJJ ARCHITECTURE, LLC

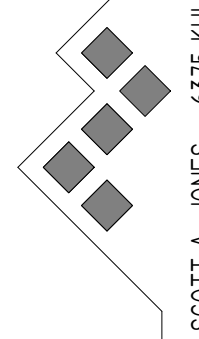

SCOTT A. JONES 6375 KULIS DRIVE, ANCHORAGE, ALASKA 99502  
#907-440-6606 #907-258-6606 (FAX)

# OUZINKIE OFFICE

## OUZINKIE NATIVE CORP

JTC  
DR: JTC/TLT  
CK: -  
DT: -  
JB: OUZINKIE  
DWG: MECHANICAL  
PLAN - MAIN  
LEVEL

# M2.1

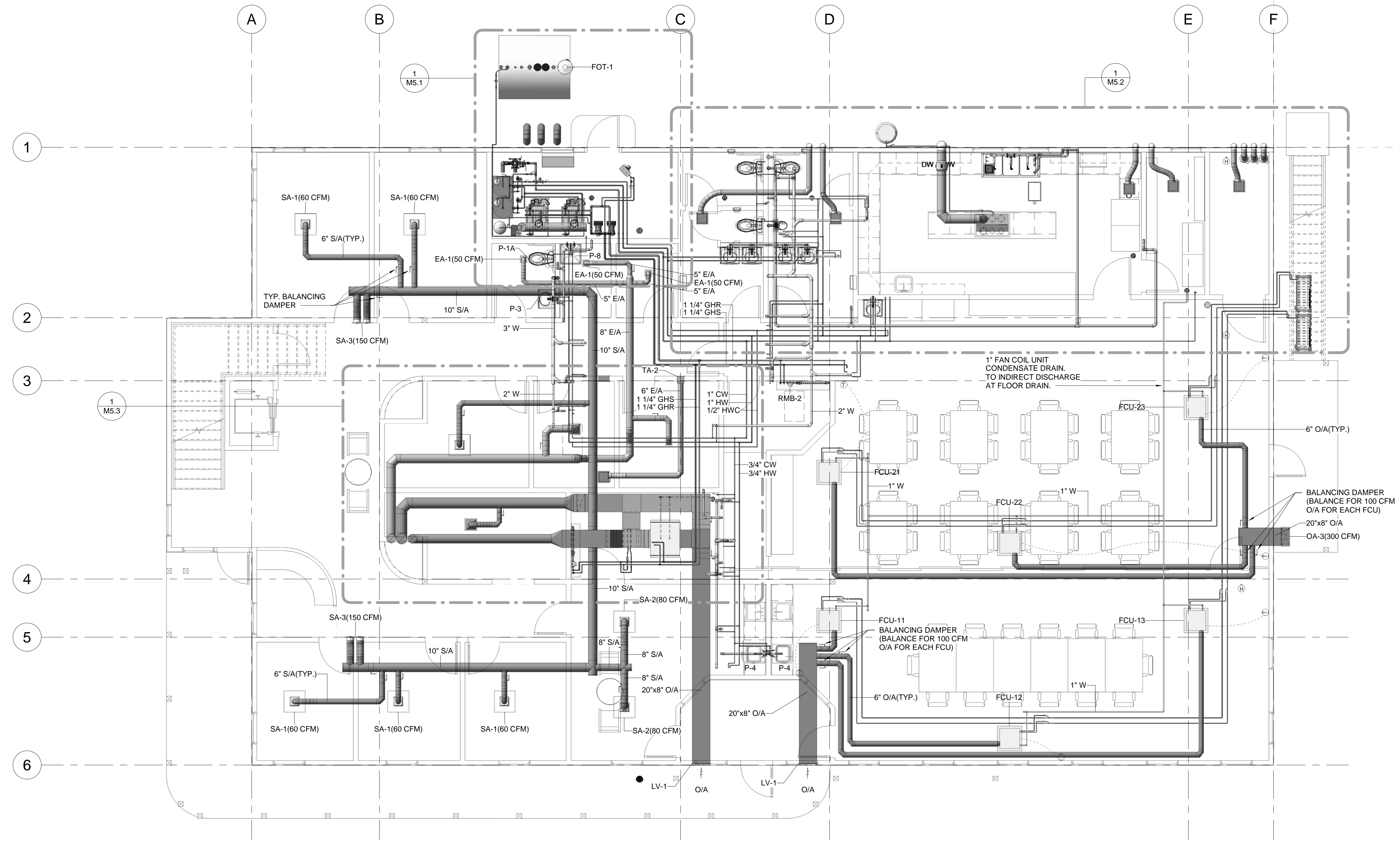

**1 MECHANICAL PLAN - MAIN LEVEL**  
Scale: 3/16" = 1'-0"

"IIX17 DRAWINGS ARE HALF THE INDICATED SCALE"



REV NO: XX DATE

**ingroup** Engineers, Inc.  
 1000 Commercial Center, Suite 200, Anchorage, Alaska 99503  
 8000 14th Avenue North, Suite 100, Fairbanks, Alaska 99709  
 State of Alaska License No. ME-8423

**SAJJ ARCHITECTURE, LLC**  
 SCOTT A. JONES 6375 KULIS DRIVE, ANCHORAGE, ALASKA 99502  
 #907-440-6606 #907-258-6606 (FAX)

**OUZINKIE OFFICE**  
**OUZINKIE NATIVE CORP**

DR: JTC  
 CK: JTC/TLT  
 DT: -  
 JB: OUZINKIE  
 DWG: MECHANICAL  
 PLAN - UPPER  
 LEVEL

**M2.2**

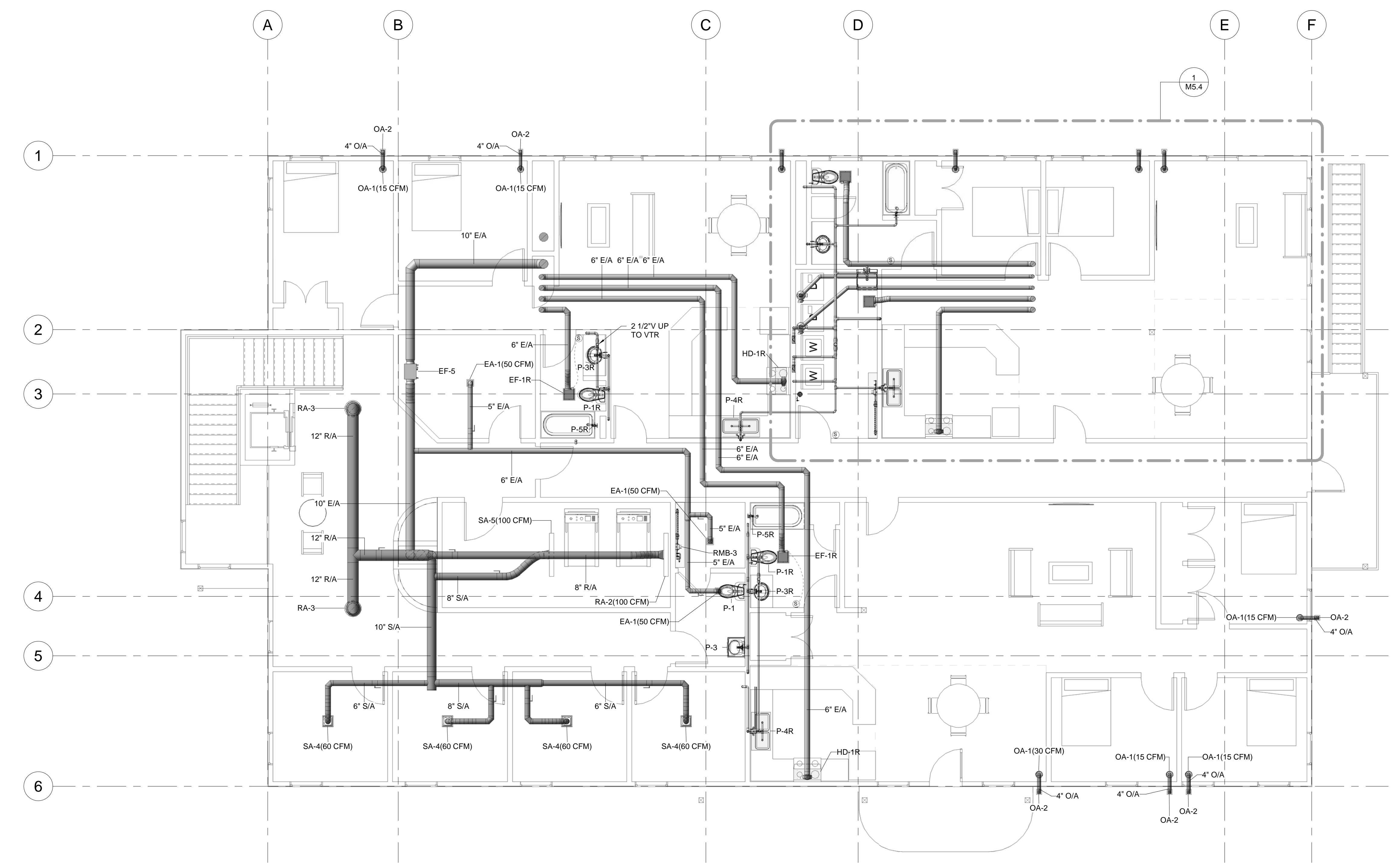

**1 MECHANICAL PLAN - UPPER LEVEL**  
 Scale: 3/16" = 1'-0"

"IIX17 DRAWINGS ARE HALF THE INDICATED SCALE"



REV NO: XX DATE



SAJJ ARCHITECTURE, LLC

SCOTT A. JONES 6375 KULIS DRIVE - ANCHORAGE, ALASKA 99502  
#907-440-6606 #907-258-6606 (FAX)

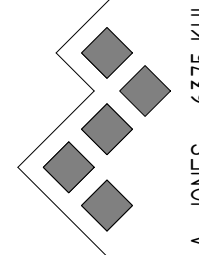

**OUZINKIE OFFICE**  
OUZINKIE NATIVE CORP

DR: JTC  
CK: JTC/TLT  
DT: -  
JB: OUZINKIE  
DWG: MECHANICAL PLAN - ROOF

**M2.3**

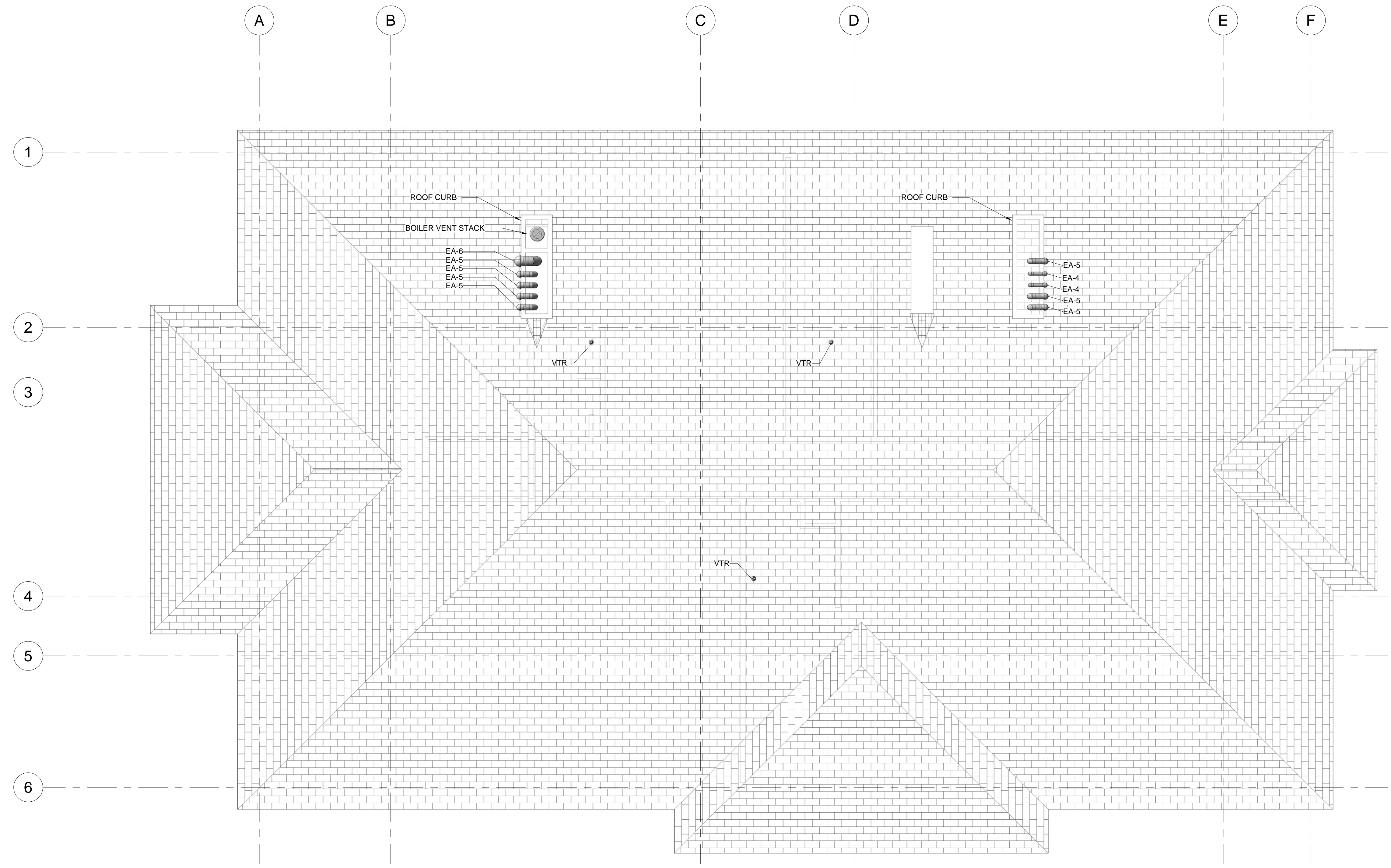

**1 MECHANICAL PLAN - ROOF**  
Scale: 3/16" = 1'-0"





REV NO: XX DATE



**SAJJ ARCHITECTURE, LLC**  
 SCOTT A. JONES 6375 KULIS DRIVE, ANCHORAGE, ALASKA 99502  
 #907-440-6606 #907-258-6606 (FAX)

**OUZINKIE OFFICE**  
 OUZINKIE NATIVE CORP

JTC  
 DR: JTC/TLT  
 CK: DT: JB: OUZINKIE  
 DWG: RADIANANT SYSTEM PLAN - MAIN LEVEL

**M3.1**

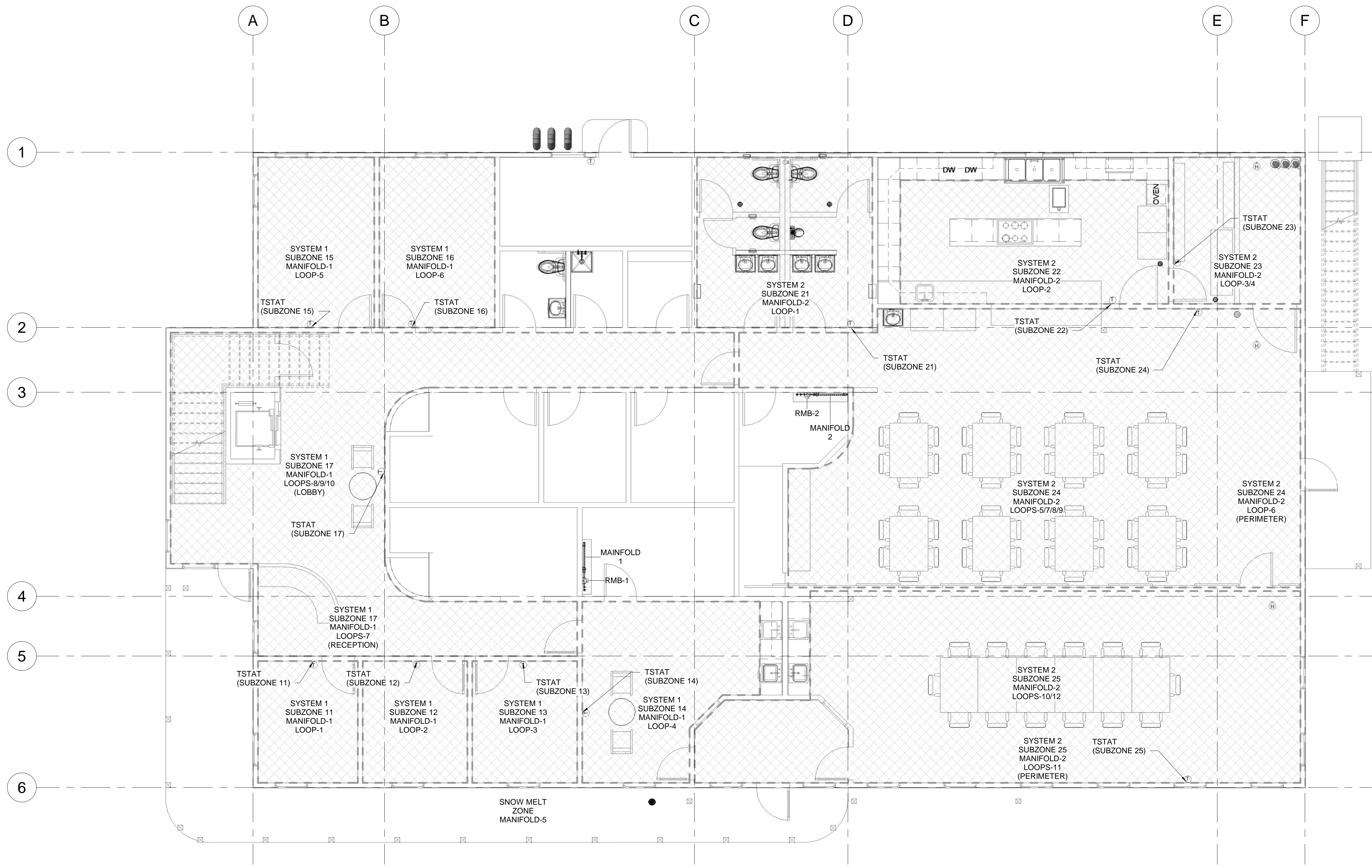

**RADIANT FLOOR SYSTEM SCHEDULE**

**SYSTEM 1 (MAIN LEVEL OFFICE AREA)**  
**RMB-1/MANIFOLD 1 - 10 LOOPS**

SUBZONE / LOOP/ROOM:	TUBE SIZE:	TUBE SPACING / LENGTH:	FLOW RATE:	PRESSURE DROP:
11 / 1 / OFFICE 1*	1/2"	12' / 130 FT	0.3 GPM	0.7 FT W.C.
12 / 2 / OFFICE 2*	1/2"	12' / 135 FT	0.2 GPM	0.3 FT W.C.
13 / 3 / OFFICE 3*	1/2"	12' / 135 FT	0.2 GPM	0.3 FT W.C.
14 / 4 / BREAK RM*	1/2"	12' / 276 FT	0.5 GPM	5.4 FT W.C.
15 / 5 / OFFICE 5*	1/2"	12' / 175 FT	0.3 GPM	1.3 FT W.C.
16 / 6 / OFFICE 6*	1/2"	12' / 205 FT	0.2 GPM	0.5 FT W.C.
17 / 7 / RECEPTION*	1/2"	12' / 215 FT	0.3 GPM	1.5 FT W.C.
17 / 8 / LOBBY*	1/2"	12' / 227 FT	0.4 GPM	2.9 FT W.C.
17 / 9 / LOBBY*	1/2"	12' / 227 FT	0.4 GPM	2.9 FT W.C.
17 / 10 / LOBBY*	1/2"	12' / 227 FT	0.4 GPM	2.9 FT W.C.
<b>TOTAL**:</b>		<b>1951 FT</b>	<b>3.2 GPM</b>	<b>5.4 FT W.C.</b>

HEATING LOAD: 28.8 MBH  
 MEAN GLYCOL TEMPERATURE: 109 DEG F  
 TEMPERATURE DIFFERENTIAL: 20 DEG F

**SYSTEM 2 (GATHERING/CONFERENCE/KITCHEN AREA)**  
**RMB-2/MANIFOLD 2 - 12 LOOPS**

SUBZONE / LOOP/ROOM:	TUBE SIZE:	TUBE SPACING / LENGTH:	FLOW RATE:	PRESSURE DROP:
21 / 1 / RESTRM*	1/2"	12' / 140 FT	0.3 GPM	0.2 FT W.C.
21 / 2 / RESTRM*	1/2"	12' / 140 FT	0.3 GPM	0.2 FT W.C.
22 / 3 / KITCHEN*	1/2"	12' / 395 FT	0.5 GPM	6.3 FT W.C.
23 / 4 / STOR/PAN*	1/2"	12' / 100 FT	0.1 GPM	0.2 FT W.C.
24 / 5 / GATHER*	1/2"	12' / 299 FT	0.2 GPM	0.9 FT W.C.
24 / 6 / GATHER*	1/2"	6' / 120 FT	0.3 GPM	0.9 FT W.C.
24 / 7 / GATHER*	1/2"	12' / 299 FT	0.2 GPM	0.9 FT W.C.
24 / 8 / GATHER*	1/2"	12' / 299 FT	0.2 GPM	0.9 FT W.C.
24 / 9 / GATHER*	1/2"	12' / 299 FT	0.2 GPM	0.9 FT W.C.
25 / 10 / CONF RM*	1/2"	12' / 325 FT	0.4 GPM	4.2 FT W.C.
25 / 11 / CONF RM*	1/2"	6' / 272 FT	0.5 GPM	4.2 FT W.C.
25 / 12 / CONF RM*	1/2"	12' / 325 FT	0.4 GPM	4.2 FT W.C.
<b>TOTAL**:</b>		<b>1951 FT</b>	<b>3.2 GPM</b>	<b>6.3 FT W.C.</b>

HEATING LOAD: 28.8 MBH  
 MEAN GLYCOL TEMPERATURE: 98 DEG F  
 TEMPERATURE DIFFERENTIAL: 20 DEG F

\*: WITH SUBZONE CONTROL THERMOSTAT AND LOOP ACTUATOR(S).  
 \*\*: LENGTH DOES NOT INCLUDE LOOP RUNOUT/TAIL.

**1 RADIANT SYSTEM PLAN - MAIN LEVEL**  
 Scale: 3/16" = 1'-0"



REV NO: XX DATE



SAJJ ARCHITECTURE, LLC

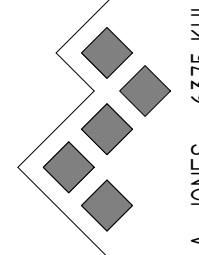

SCOTT A. JONES 6375 KULIS DRIVE, ANCHORAGE, ALASKA 99502  
#907-440-6606 #907-258-6606 (FAX)

**OUZINKIE OFFICE**  
OUZINKIE NATIVE CORP

JTC  
DR: JTC/TLT  
CK: DT: JB: OUZINKIE  
DWG: RADIANT FLOOR SYSTEM PLAN - UPPER LEVEL

M3.2

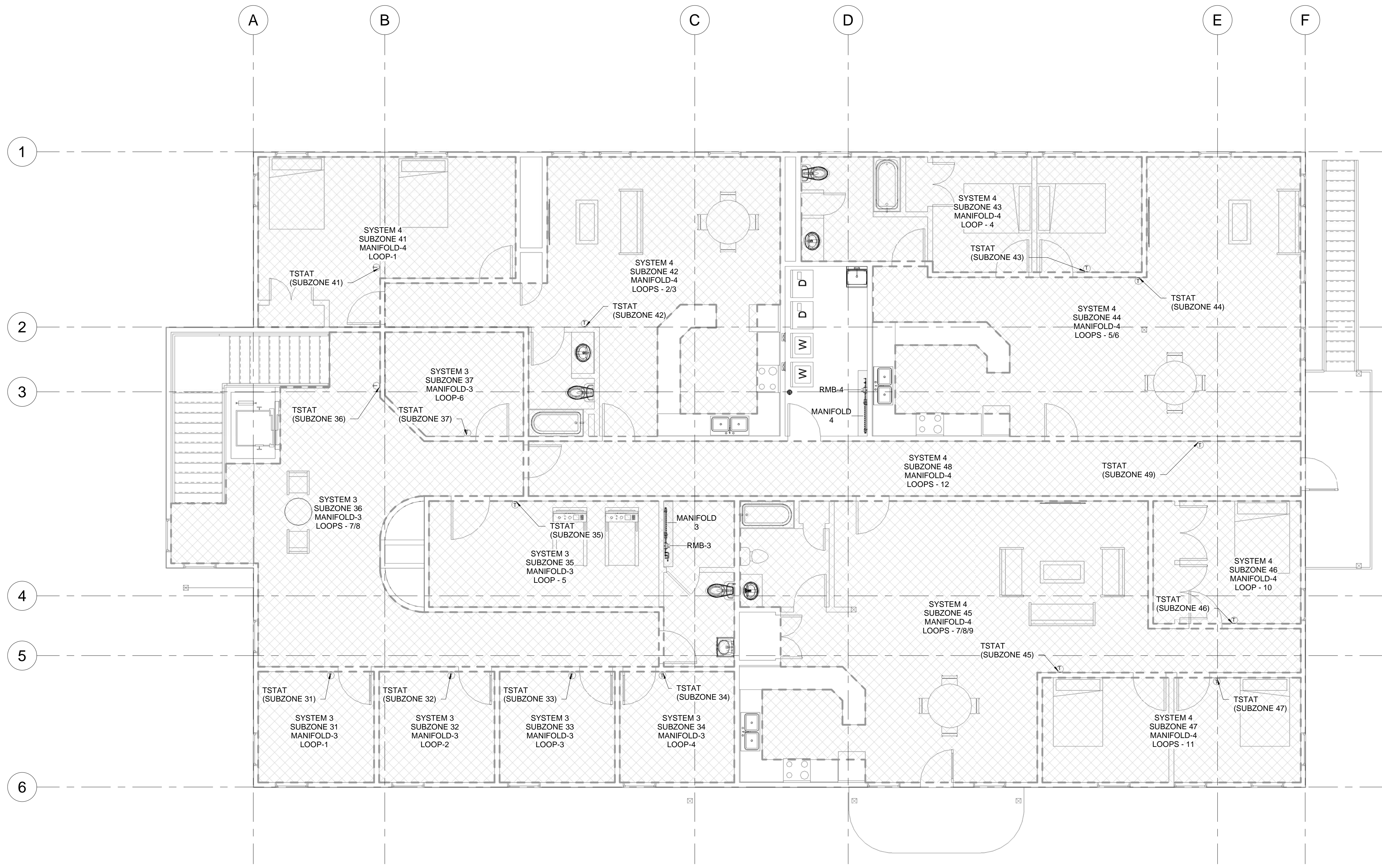

**RADIANT FLOOR SYSTEM SCHEDULE**

**SYSTEM 3 (UPPER LEVEL OFFICE AREA)  
RMB-1/MANIFOLD 1 - 8 LOOPS**

SUBZONE /LOOP/ROOM:	TUBE SIZE:	TUBE SPACING /LENGTH	FLOW RATE:	PRESSURE DROP:
31 / 1 / OFFICE 1*	1/2"	8" / 170 FT	0.2 GPM	0.5 FT W.C.
32 / 2 / OFFICE 2*	1/2"	12" / 120 FT	0.1 GPM	0.2 FT W.C.
33 / 3 / OFFICE 3*	1/2"	12" / 120 FT	0.1 GPM	0.2 FT W.C.
34 / 4 / OFFICE 4*	1/2"	12" / 120 FT	0.1 GPM	0.2 FT W.C.
35 / 5 / EXERCISE*	1/2"	12" / 225 FT	0.1 GPM	0.4 FT W.C.
36 / 6 / STORAGE*	1/2"	12" / 135 FT	0.1 GPM	0.2 FT W.C.
37 / 7 / LOBBY*	1/2"	12" / 295 FT	0.2 GPM	1.2 FT W.C.
37 / 8 / LOBBY*	1/2"	12" / 295 FT	0.2 GPM	1.2 FT W.C.
<b>TOTAL**:</b>		<b>1480 FT</b>	<b>1.1 GPM</b>	<b>1.2 FT W.C.</b>

HEATING LOAD: 9.9 MBH  
MEAN GLYCOL TEMPERATURE: 95 DEG F  
TEMPERATURE DIFFERENTIAL: 20 DEG F

**SYSTEM 4 (RESIDENCES)  
RMB-4/MANIFOLD 4 - 12 LOOPS**

SUBZONE /LOOP/ROOM:	TUBE SIZE:	TUBE SPACING /LENGTH	FLOW RATE:	PRESSURE DROP:
(RESIDENT UNIT 3) 41 / 1 / BDRMS/BATH*	1/2"	8" / 463 FT	0.6 GPM	10.7 FT W.C.
42 / 2 / LVG RM*	1/2"	12" / 382 FT	0.4 GPM	3.2 FT W.C.
42 / 3 / LVG RM*	1/2"	12" / 382 FT	0.4 GPM	3.2 FT W.C.
(RESIDENT UNIT 2) 43 / 4 / BDRMS/BATH*	1/2"	8" / 423 FT	0.6 GPM	9.5 FT W.C.
44 / 5 / LVG RM*	1/2"	12" / 382 FT	0.5 GPM	6.9 FT W.C.
44 / 6 / LVG RM*	1/2"	12" / 382 FT	0.5 GPM	6.9 FT W.C.
(RESIDENT UNIT 1) 45 / 7 / LVG RM*	1/2"	12" / 293 FT	0.4 GPM	3.9 FT W.C.
45 / 8 / LVG/BATH*	1/2"	12" / 373 FT	0.5 GPM	6.2 FT W.C.
45 / 9 / LVG RM*	1/2"	12" / 293 FT	0.4 GPM	3.9 FT W.C.
46 / 10 / BDRM 3*	1/2"	12" / 245 FT	0.2 GPM	1.0 FT W.C.
47 / 11 / BDRMS 1/2*	1/2"	12" / 350 FT	0.4 GPM	4.6 FT W.C.
(LAUNDRY) 48 / 12 / LAUNDRY*	1/2"	12" / 370 FT	0.2 GPM	1.9 FT W.C.
<b>TOTAL**:</b>		<b>1951 FT</b>	<b>3.2 GPM</b>	<b>6.3 FT W.C.</b>

HEATING LOAD: 45.9 MBH  
MEAN GLYCOL TEMPERATURE: 104 DEG F  
TEMPERATURE DIFFERENTIAL: 20 DEG F

\*: WITH SUBZONE CONTROL THERMOSTAT AND LOOP ACTUATOR(S).  
\*\*: LENGTH DOES NOT INCLUDE LOOP RUNOUT/TAIL.

**1 RADIANT SYSTEM PLAN - UPPER LEVEL**  
Scale: 3/16" = 1'-0"



REV NO: XX DATE



SAJJ ARCHITECTURE, LLC

SCOTT A. JONES 6375 KULIS DRIVE, ANCHORAGE, ALASKA 99502  
#907-440-6606 #907-258-6606 (FAX)

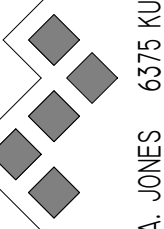

**OUZINKIE OFFICE**  
OUZINKIE NATIVE CORP

JTC  
DR: JTC/TLT  
CK: -  
DT: -  
JB: OUZINKIE  
DWG: MECHANICAL  
VIEW - BUILDING,  
VIEW 1

**M4.1**

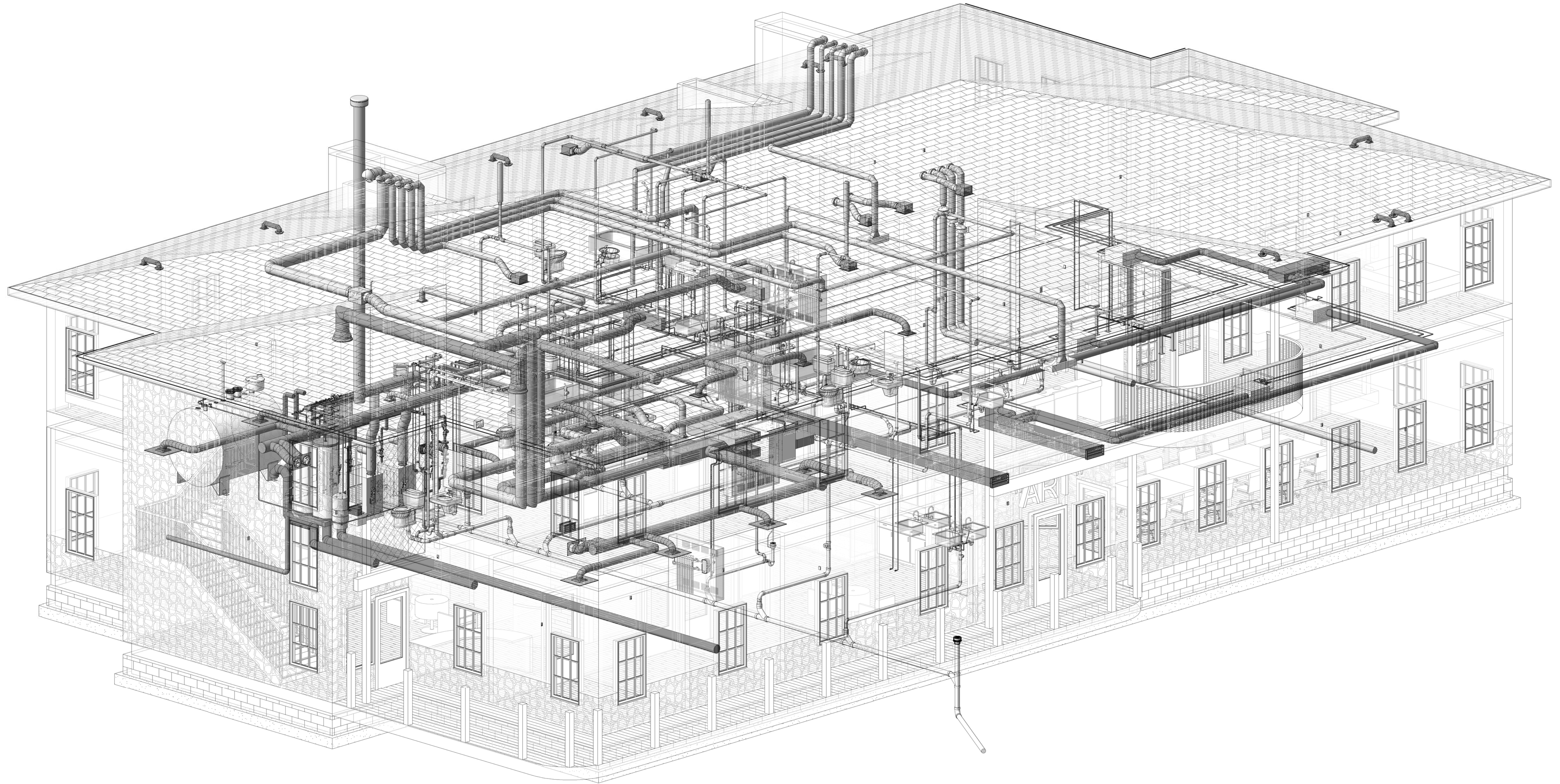

**1** MECHANICAL VIEW - BUILDING (VIEW ANGLE 1)  
Scale:

"IIX17 DRAWINGS ARE HALF THE INDICATED SCALE"

\* 31 OCTOBER 2017 \* BID SET \*



REV NO: XX DATE



SAJJ ARCHITECTURE, LLC

SCOTT A. JONES 6375 KULIS DRIVE, ANCHORAGE, ALASKA 99502  
#907-440-6606 #907-258-6606 (FAX)

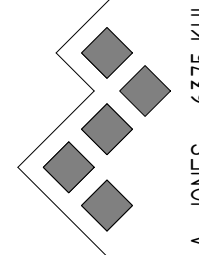

# OUZINKIE OFFICE

OUZINKIE NATIVE CORP

DR: JTC  
CK: JTC/TLT  
DT: -  
JB: OUZINKIE  
DWG: MECHANICAL  
VIEW - BUILDING,  
VIEW 2

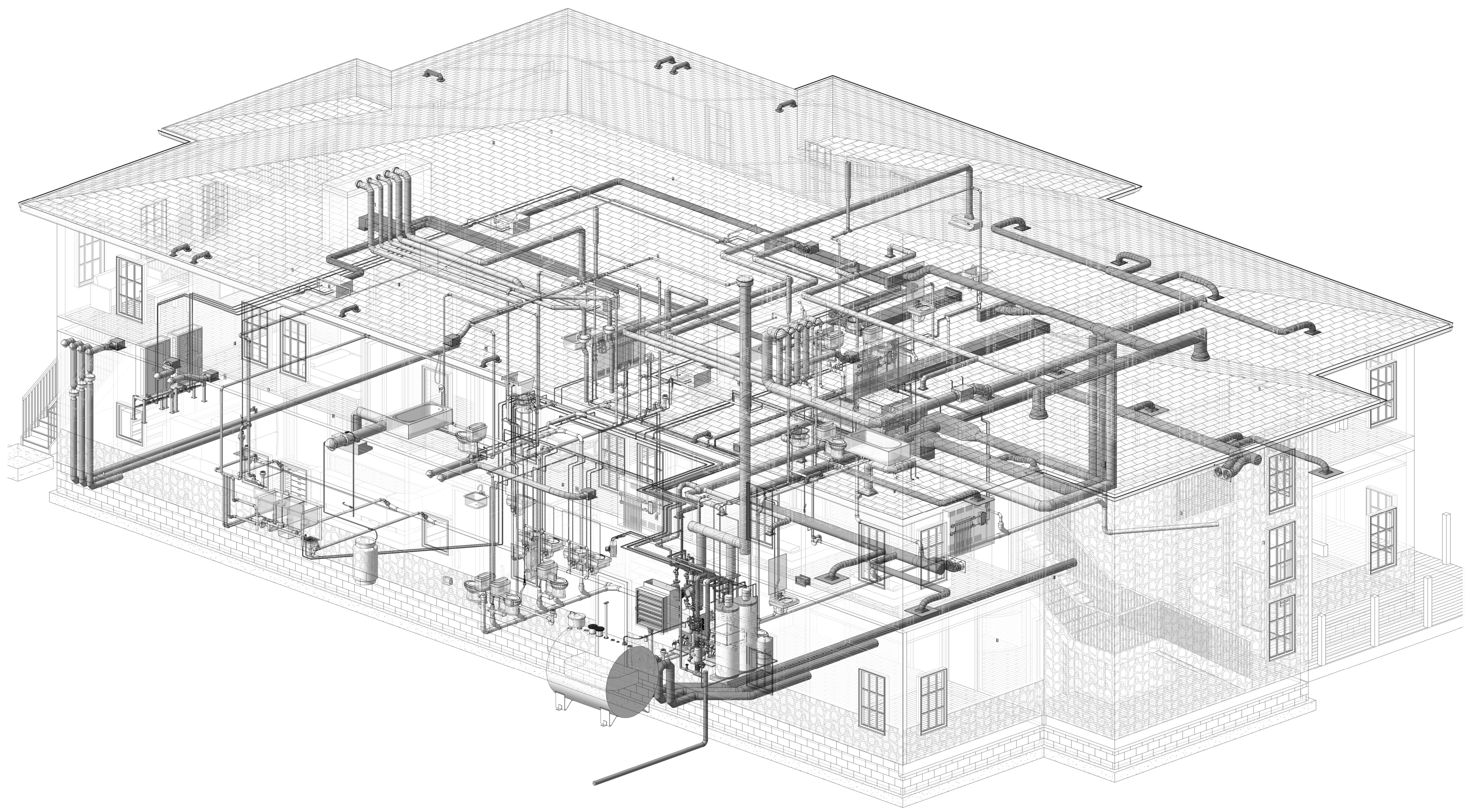

1 MECHANICAL VIEW - BUILDING (VIEW ANGLE 2)  
Scale:

"1/8" = 1' DRAWINGS ARE HALF THE INDICATED SCALE"

## M4.2

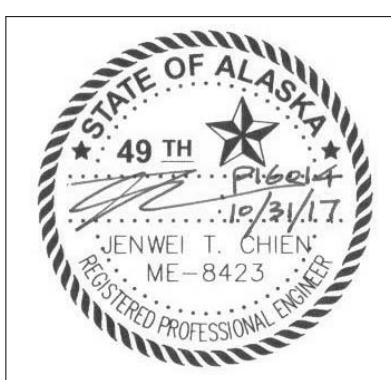

REV NO: XX  
DATE

**ingroup** engineers, inc.  
1000 Commercial Center Drive, Anchorage, Alaska 99503  
907-562-1111  
SAJJ ARCHITECTURE, LLC  
SCOTT A. JONES 6375 KULIS DRIVE, ANCHORAGE, ALASKA 99502  
#907-440-6606 #907-258-6606 (FAX)

**OUZINKIE OFFICE**  
OUZINKIE NATIVE CORP

JTC  
DR: JTC/TLT  
CK: DT  
DT: JB  
OUZINKIE  
DWG: MECHANICAL AREA PLANS(V)  
VIEWS

**M5.1**

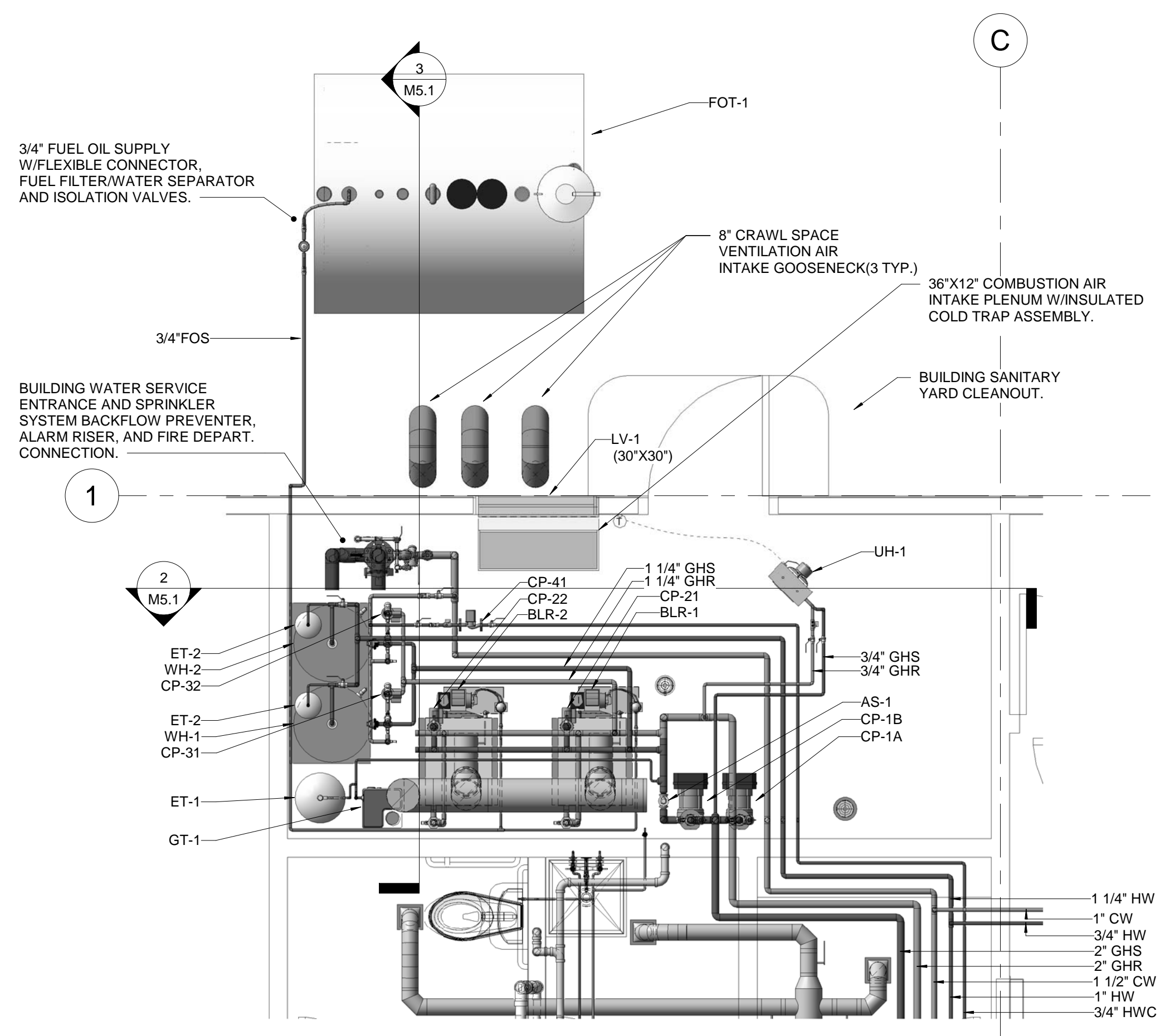

**1 MECHANICAL AREA PLAN - MECHANICAL ROOM**  
Scale: 3/8" = 1'-0"

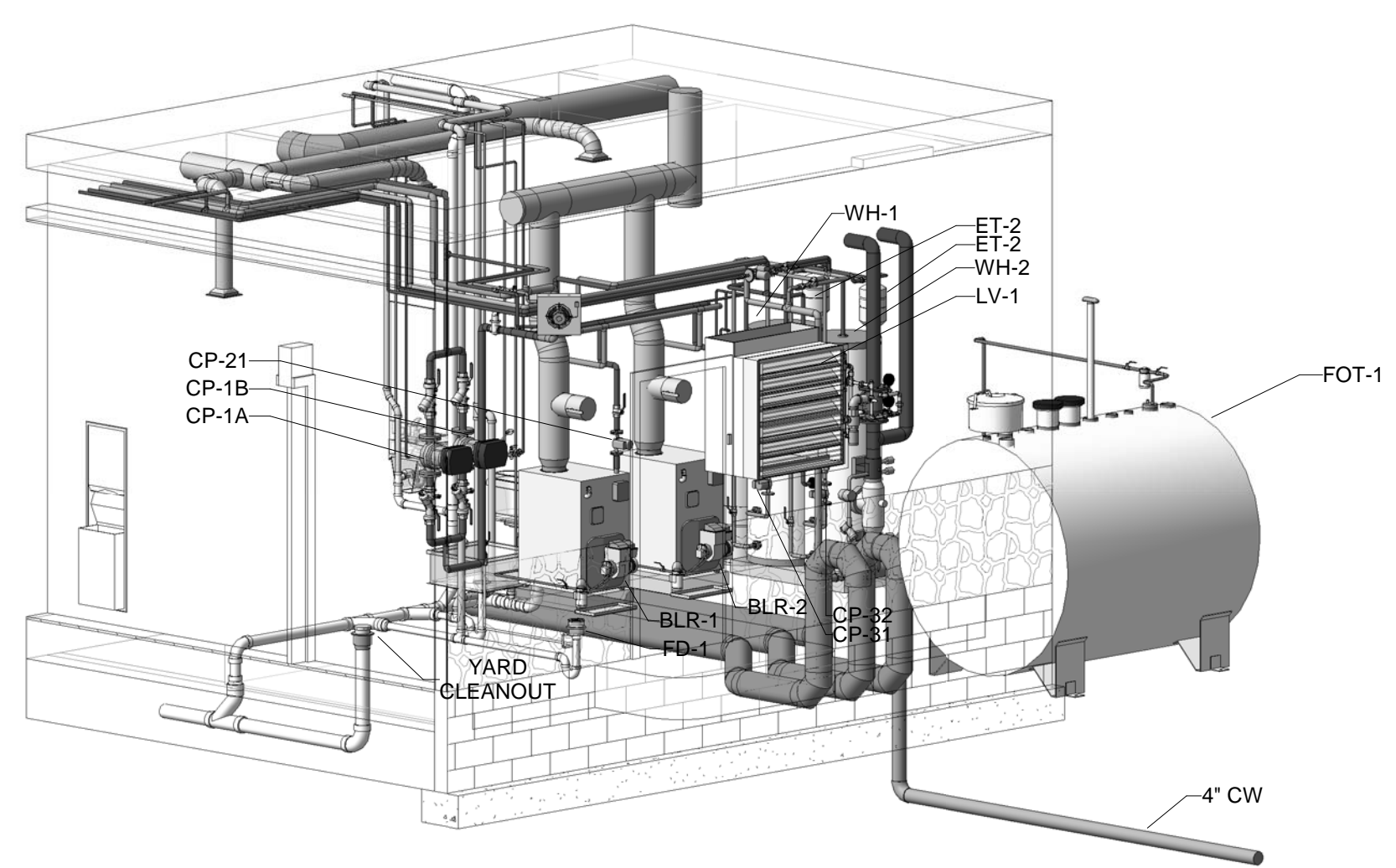

**4 MECHANICAL VIEW - MECHANICAL ROOM AREA**  
Not to Scale

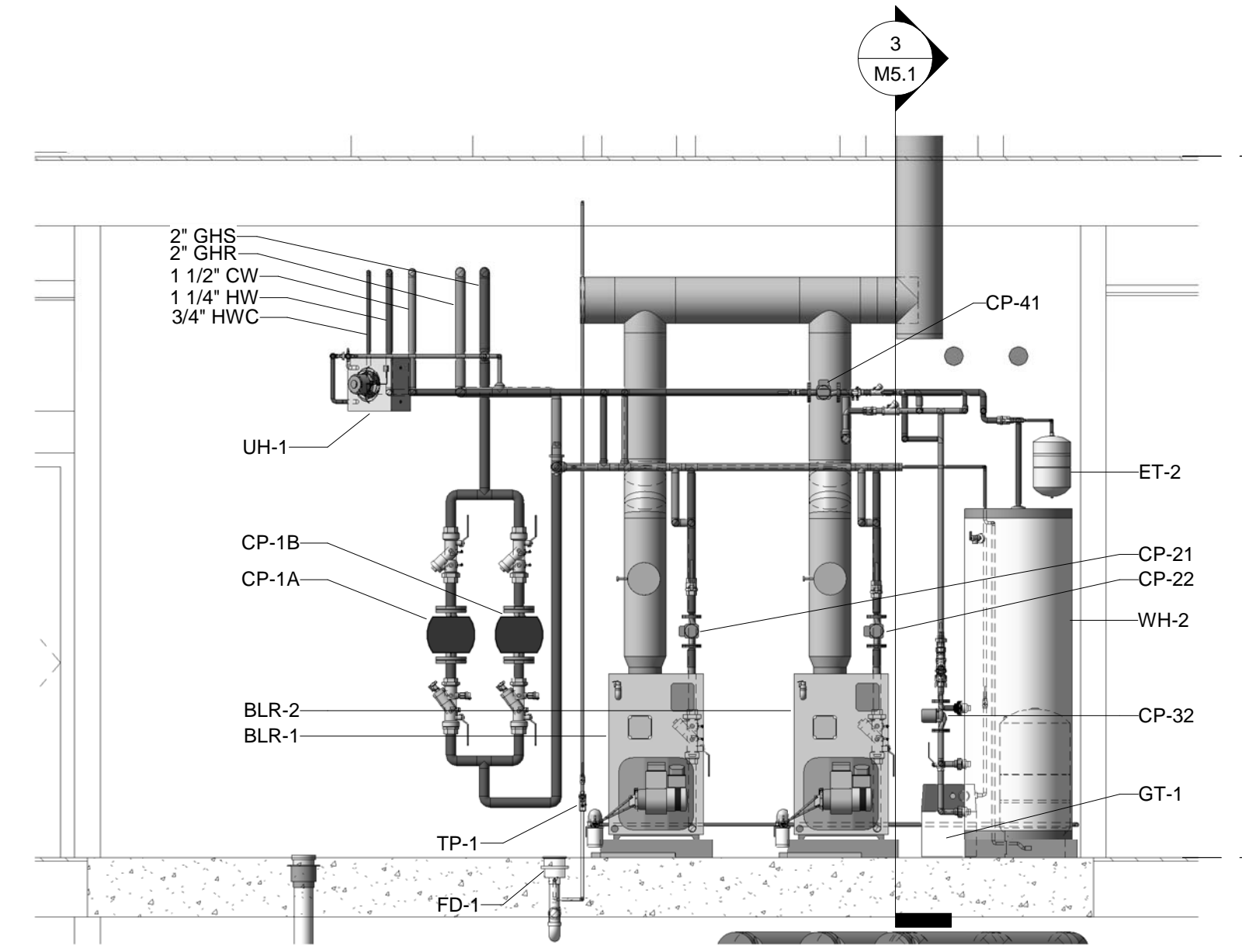

**2 MECH SECTION - MECH ROOM, SECTION 1**  
Scale: 3/8" = 1'-0"

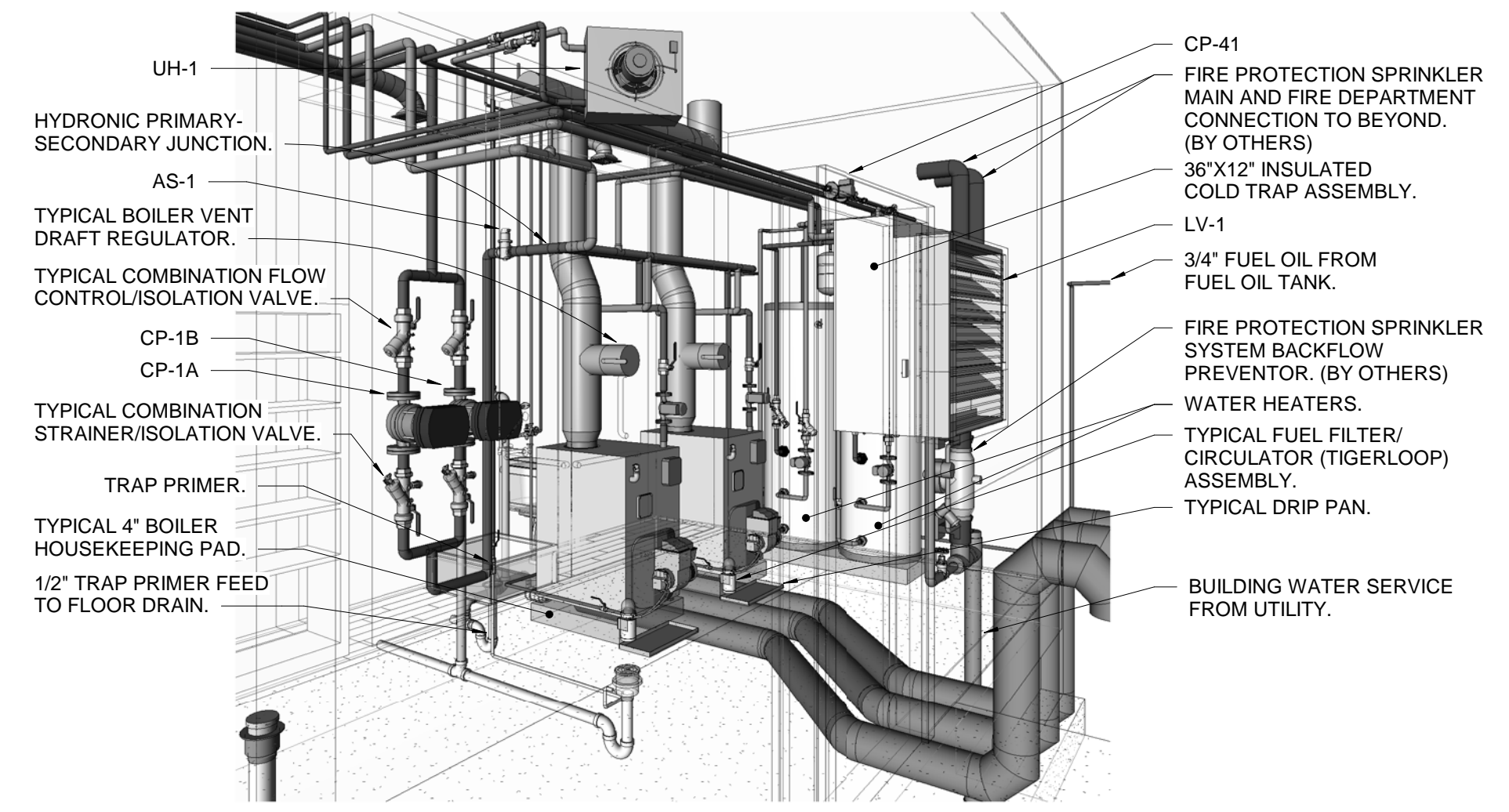

**5 3D VIEW - MECHANICAL ROOM**  
Not to Scale

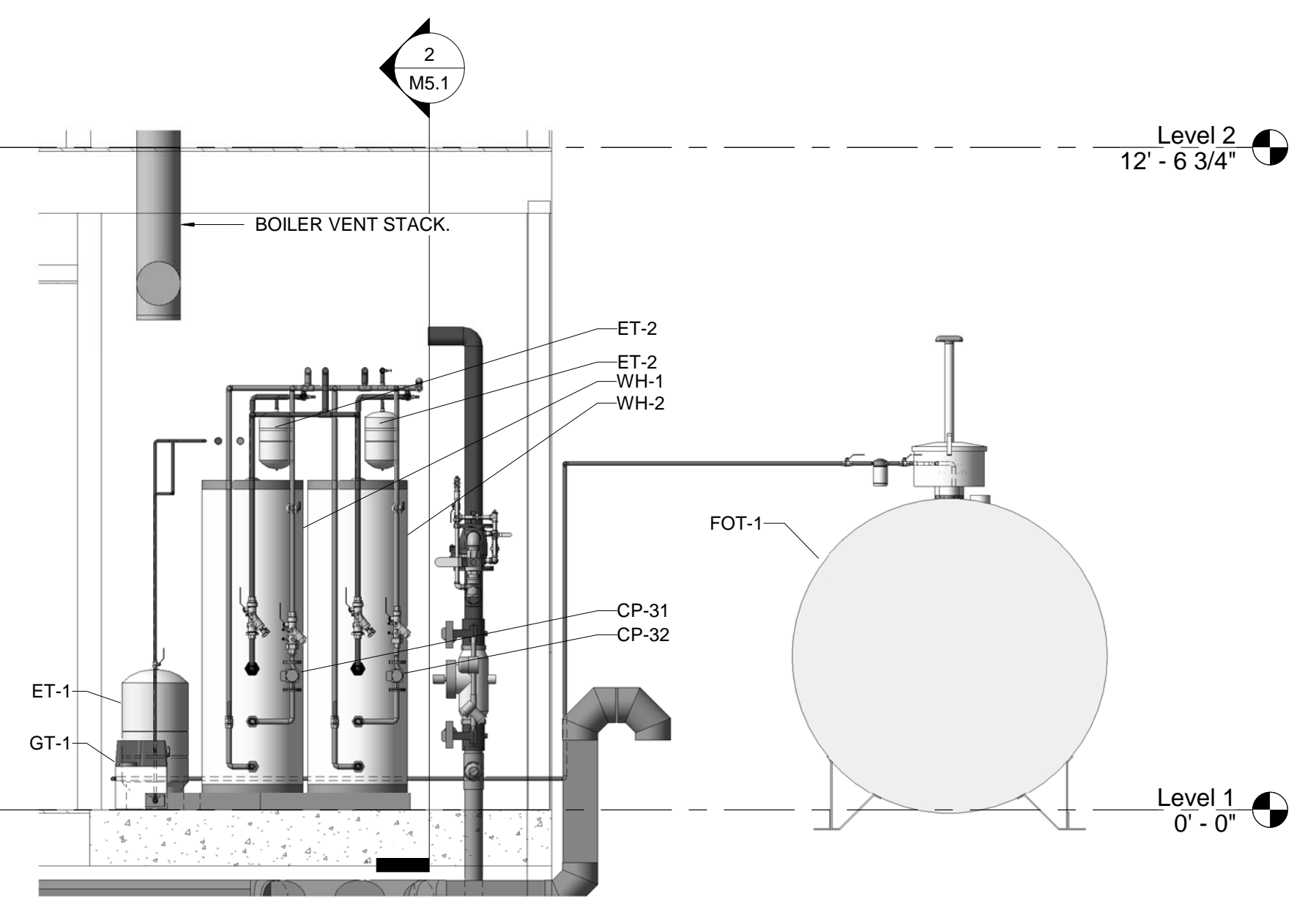

**3 MECH SECTION - MECH ROOM, SECTION 2**  
Scale: 3/8" = 1'-0"

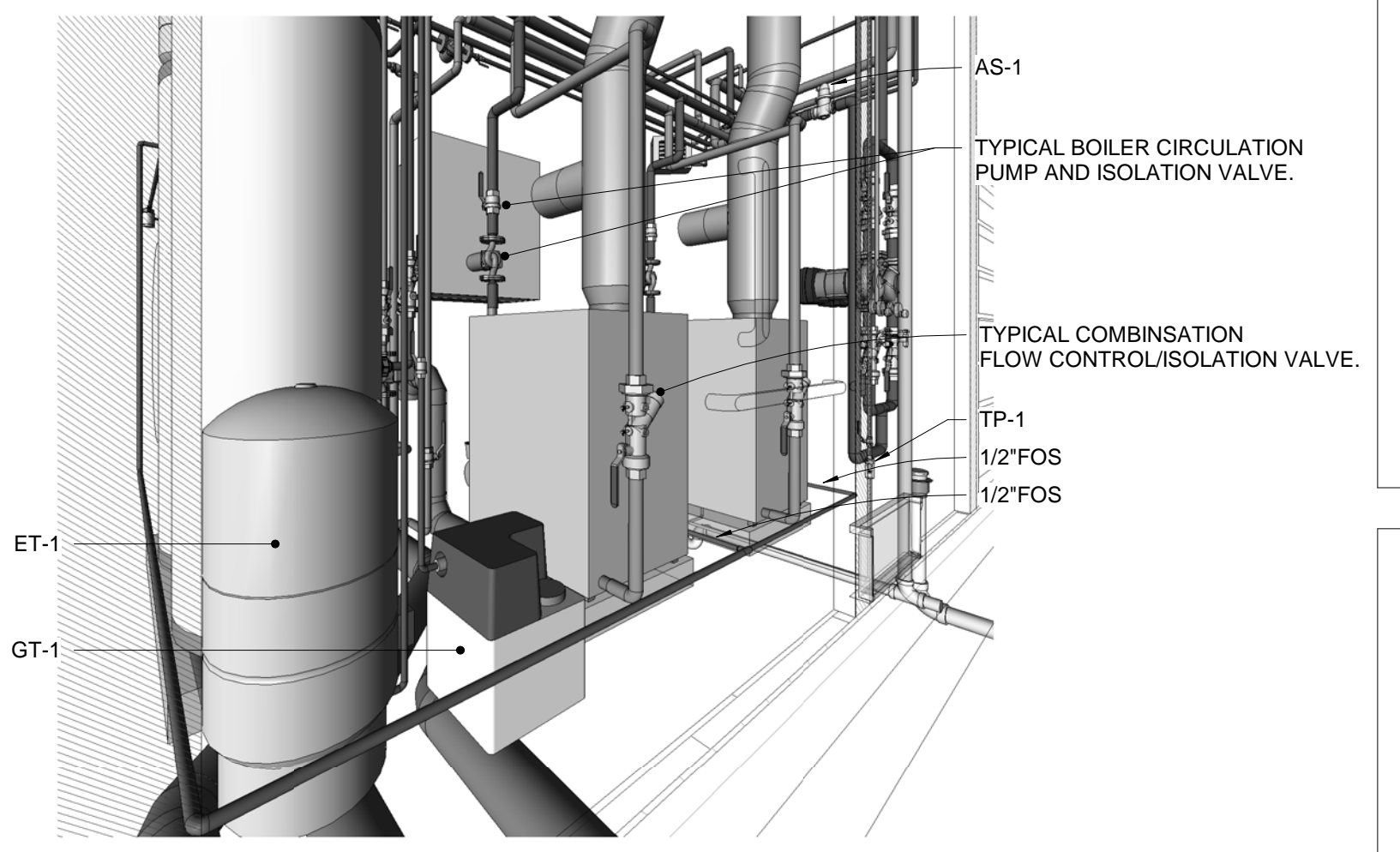

**6 3D VIEW - REAR OF BOILERS**  
Not to Scale

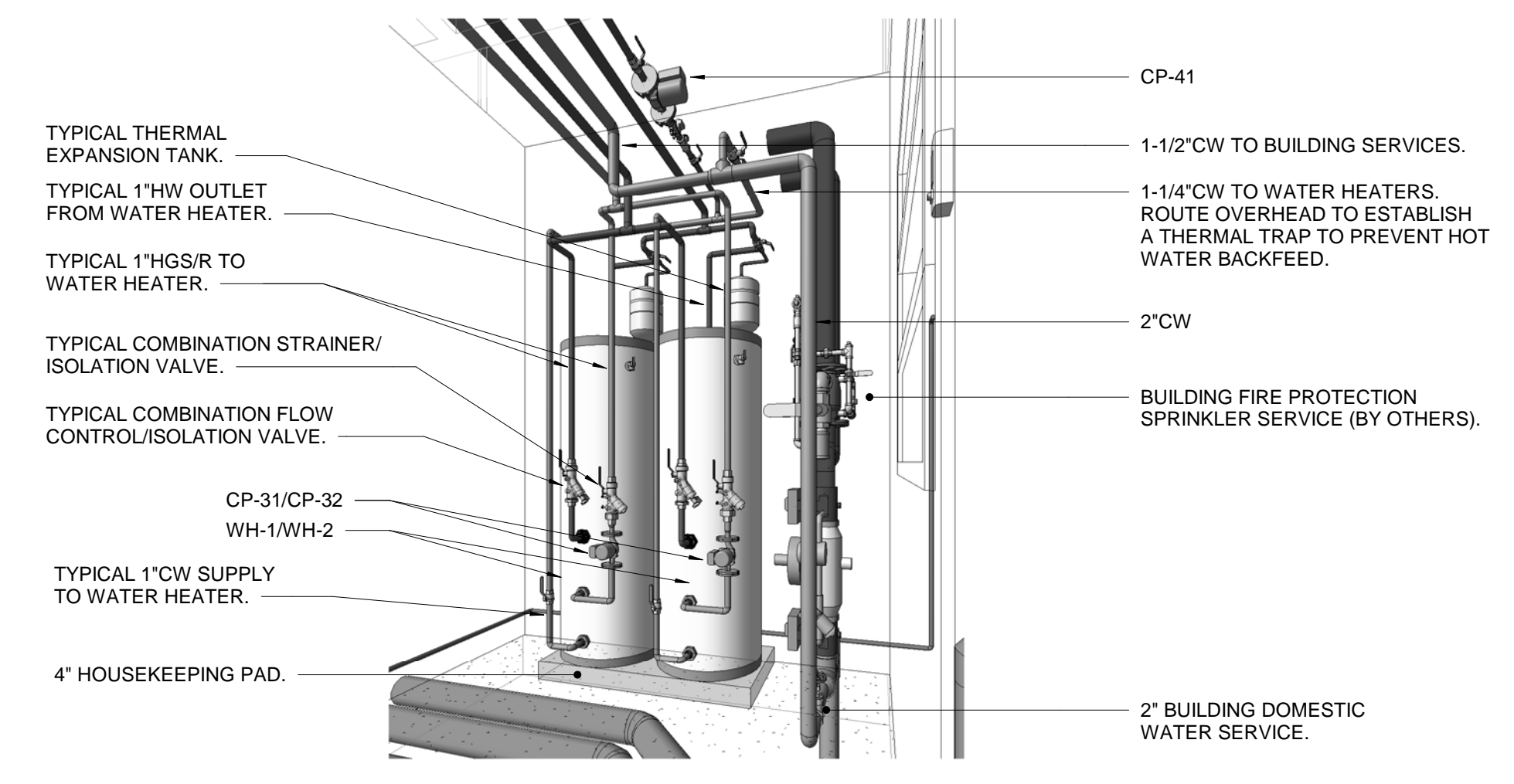

**7 3D VIEW - WATER HEATERS**  
Not to Scale



REV NO: XX  
DATE



**SAJJ ARCHITECTURE, LLC**

SCOTT A. JONES 6375 KULIS DRIVE, ANCHORAGE, ALASKA 99502  
#907-440-6606 #907-258-6606 (FAX)

**OUZINKIE OFFICE**  
OUZINKIE NATIVE CORP

JTC  
DR: JTC/TLT  
CK: DT: JB: OUZINKIE  
DWG: MECHANICAL AREA PLAN(S), VIEWS

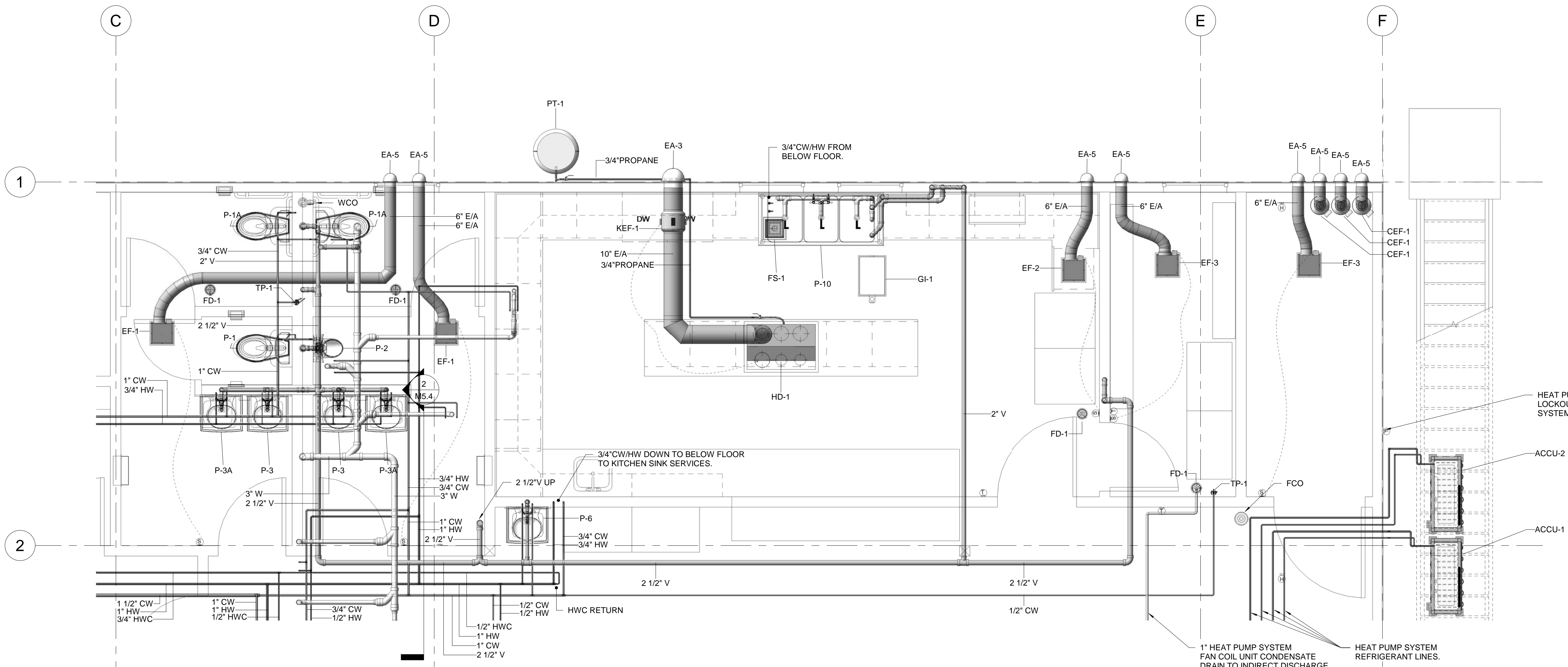

**1 MECHANICAL AREA PLAN - KITCHEN/RESTROOMS AREA**  
Scale: 3/8" = 1'-0"

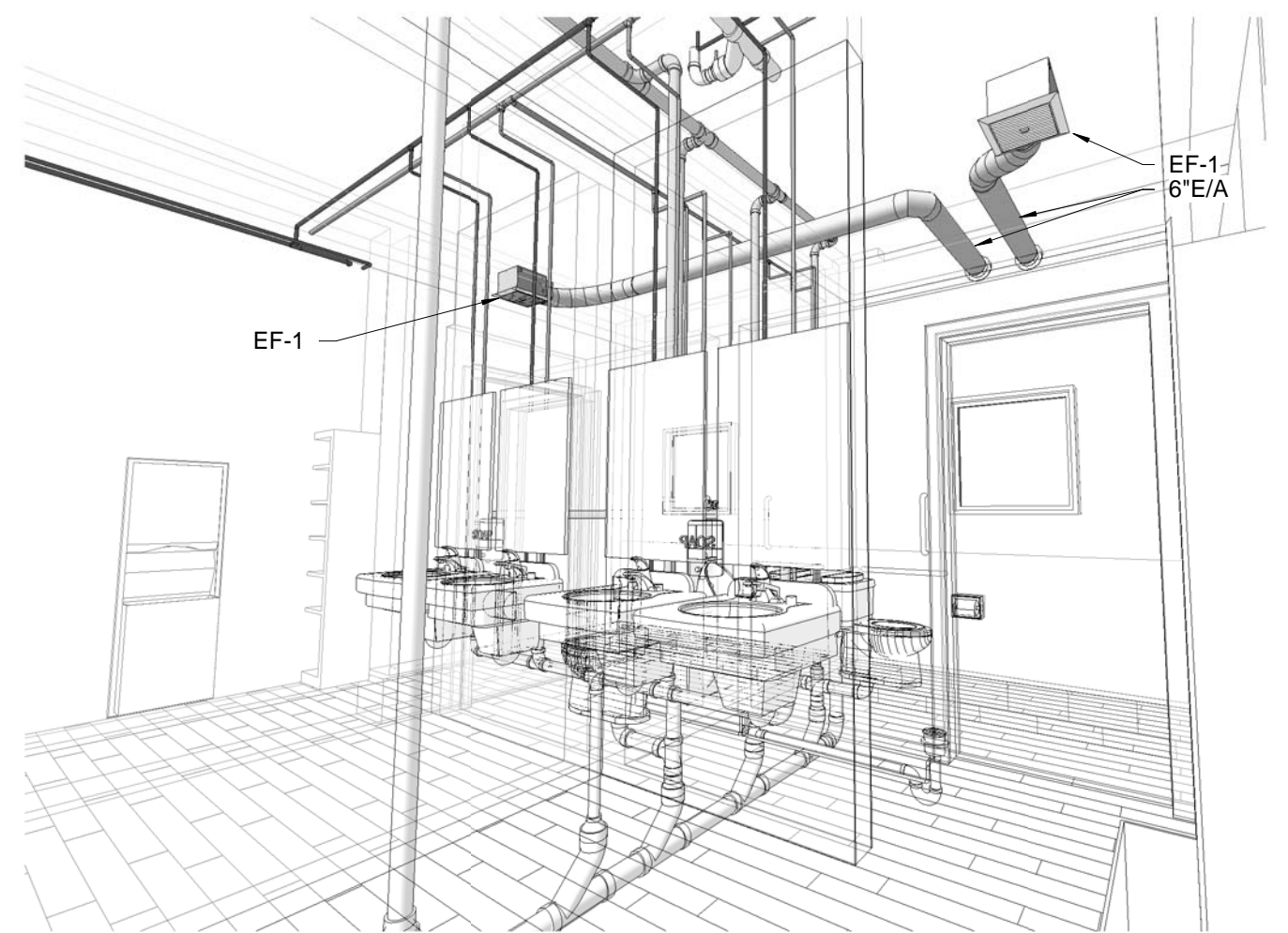

**2 3D VIEW - RESTROOMS AREA**  
Not to Scale

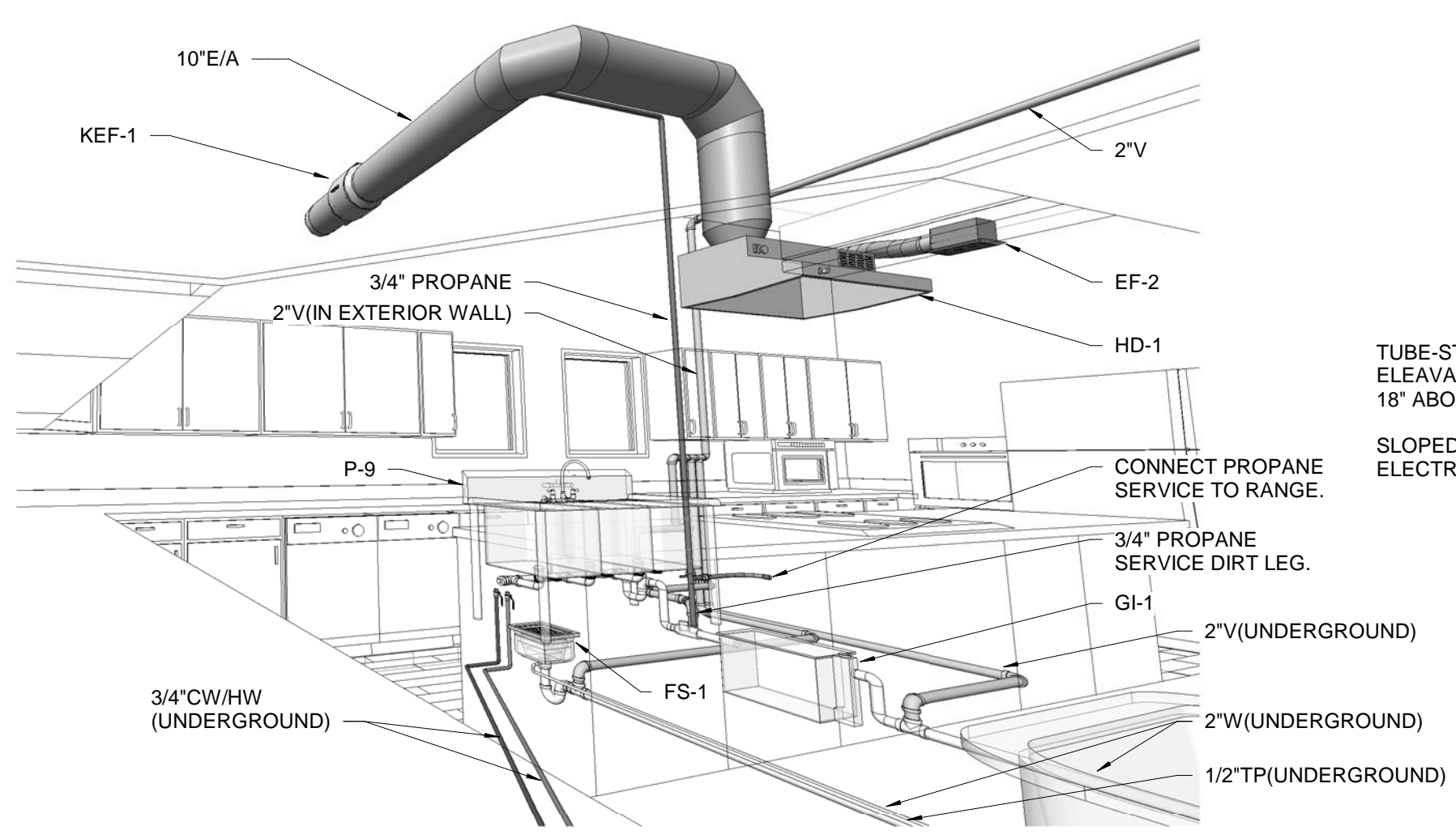

**3 3D VIEW - WARMING KITCHEN AREA**  
Not to Scale

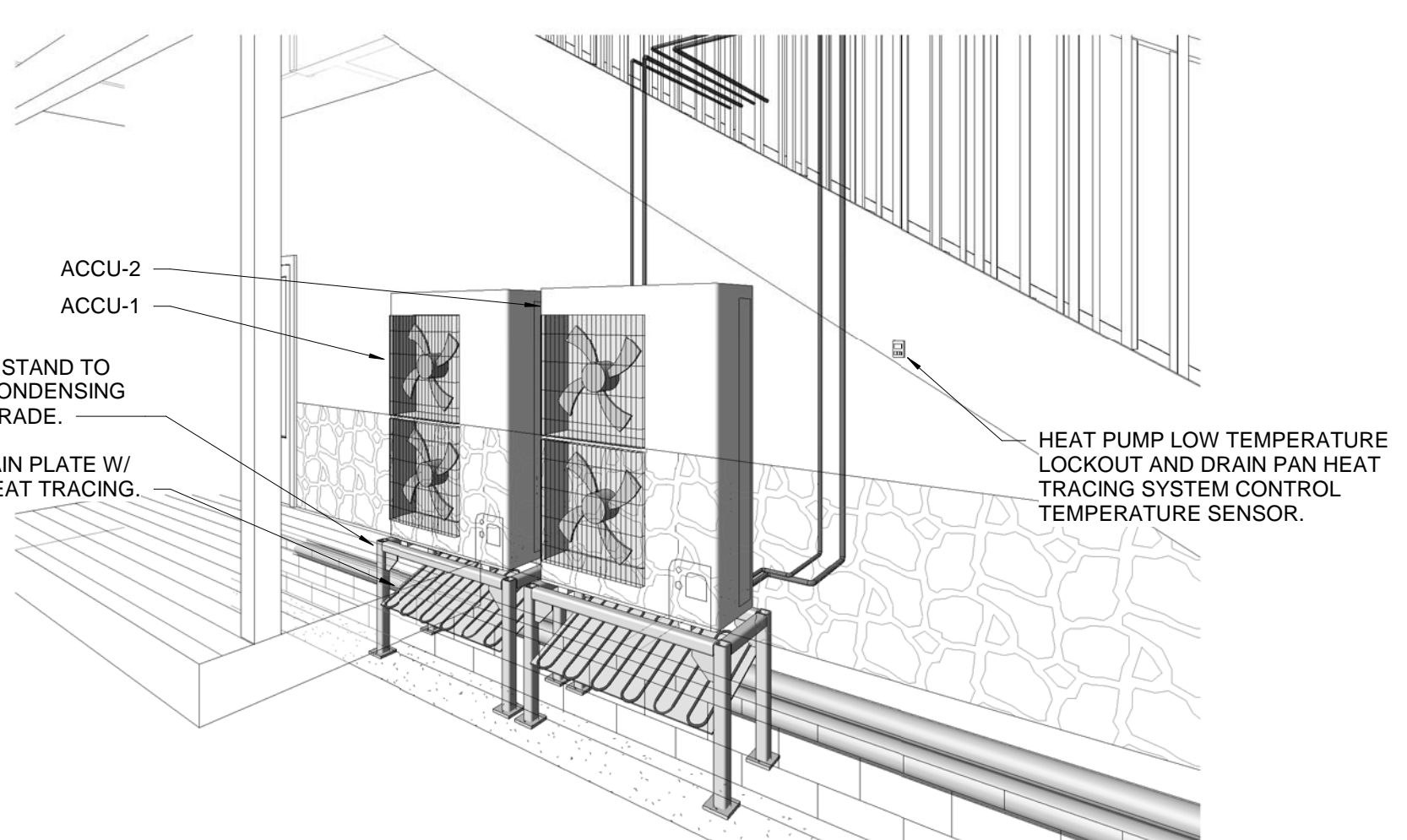

**4 3D VIEW - HEAT PUMP OUTDOOR UNITS**  
Not to Scale



REV NO: XX  
DATE



**SAJJ ARCHITECTURE, LLC**  
 SCOTT A. JONES 6375 KULIS DRIVE, ANCHORAGE, ALASKA 99502  
 #907-440-6606 #907-258-6606 (FAX)

**OUZINKIE OFFICE**  
 OUZINKIE NATIVE CORP

DR: JTC  
 CK: JTC/TLT  
 DT: -  
 JB: OUZINKIE  
 DWG: MECHANICAL AREA PLANS(V), VIEWS

**M5.3**

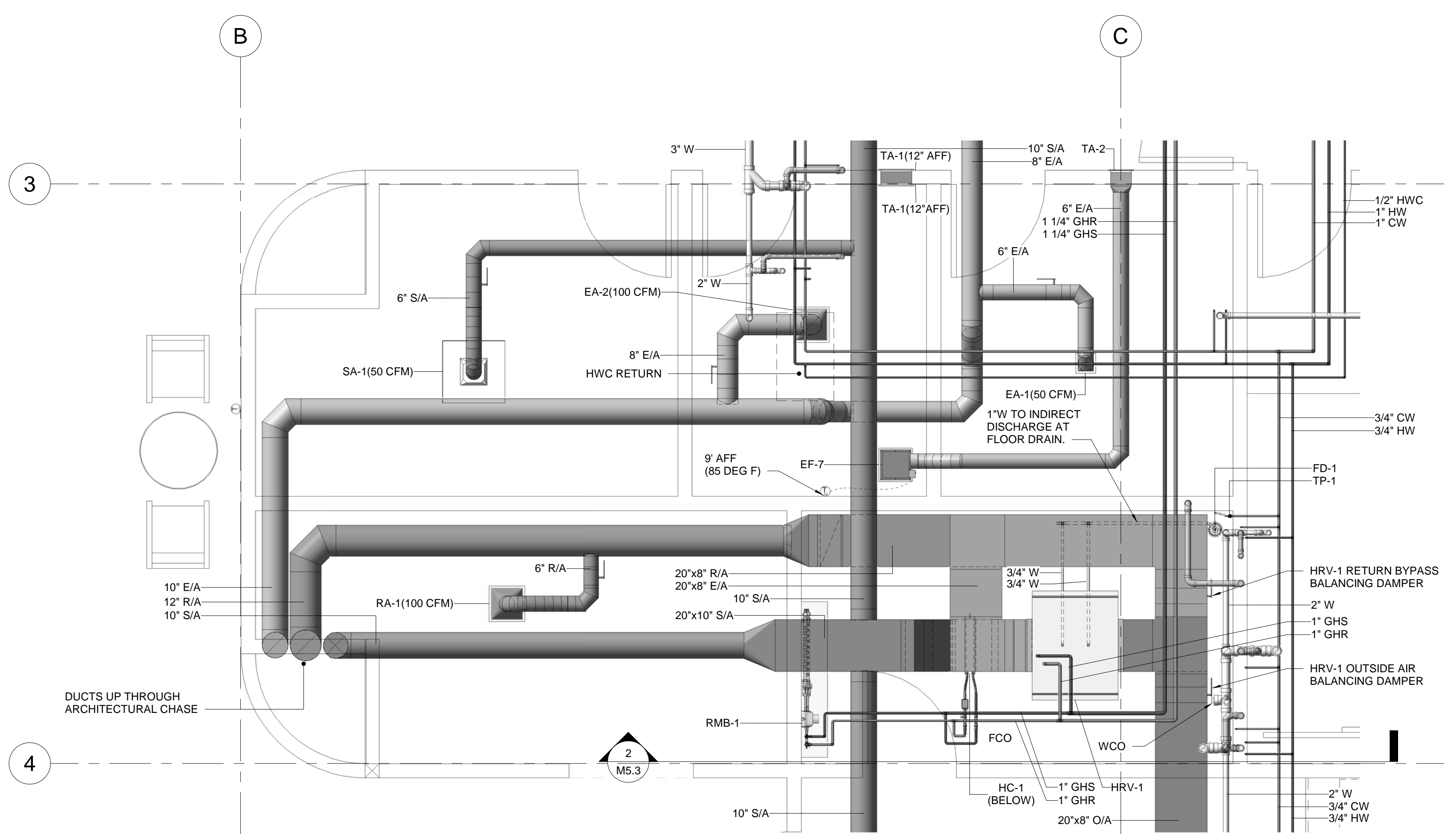

**1 MECHANICAL AREA PLAN - HRV-1 SYSTEM**  
 Scale: 3/8" = 1'-0"

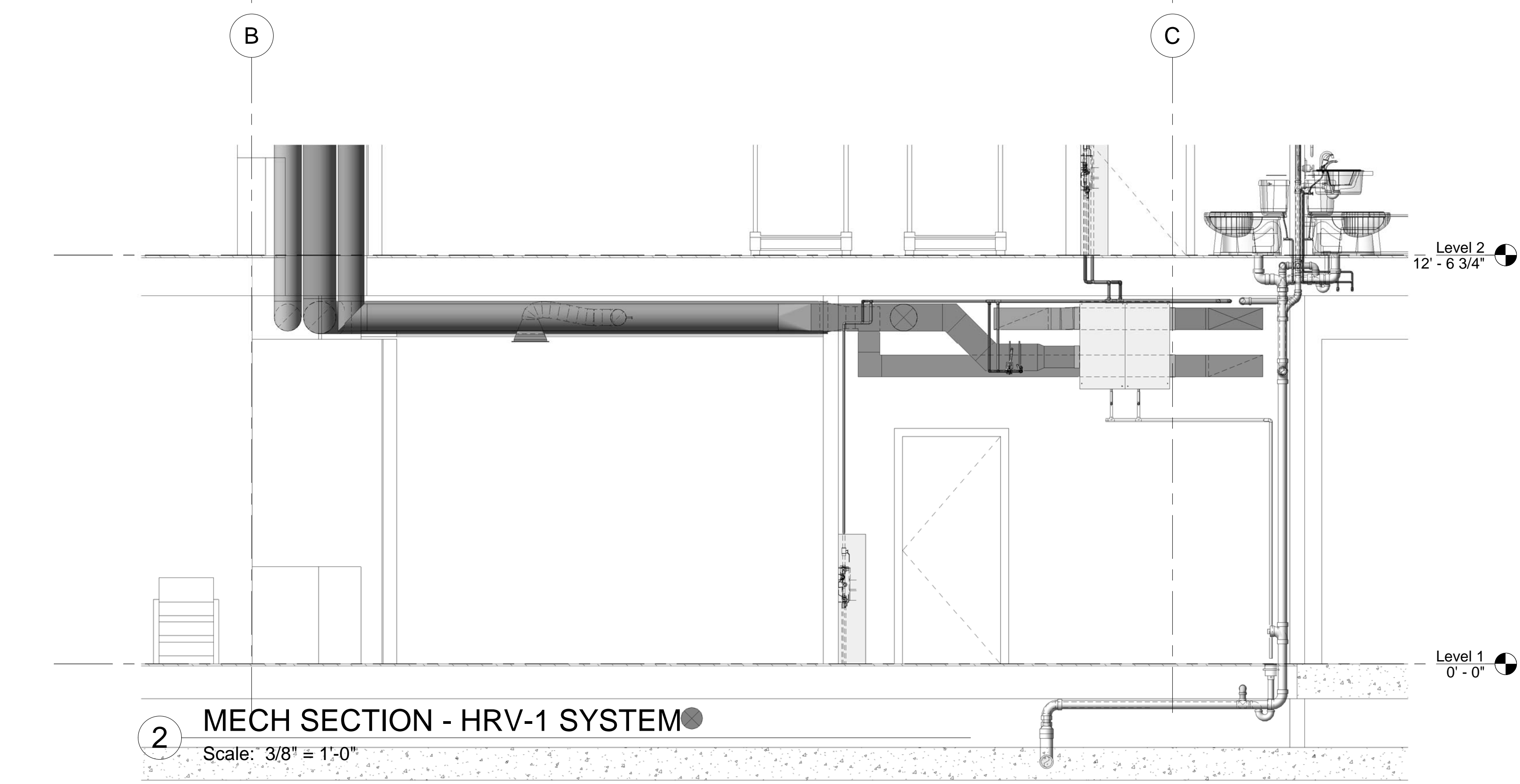

**2 MECH SECTION - HRV-1 SYSTEM**  
 Scale: 3/8" = 1'-0"

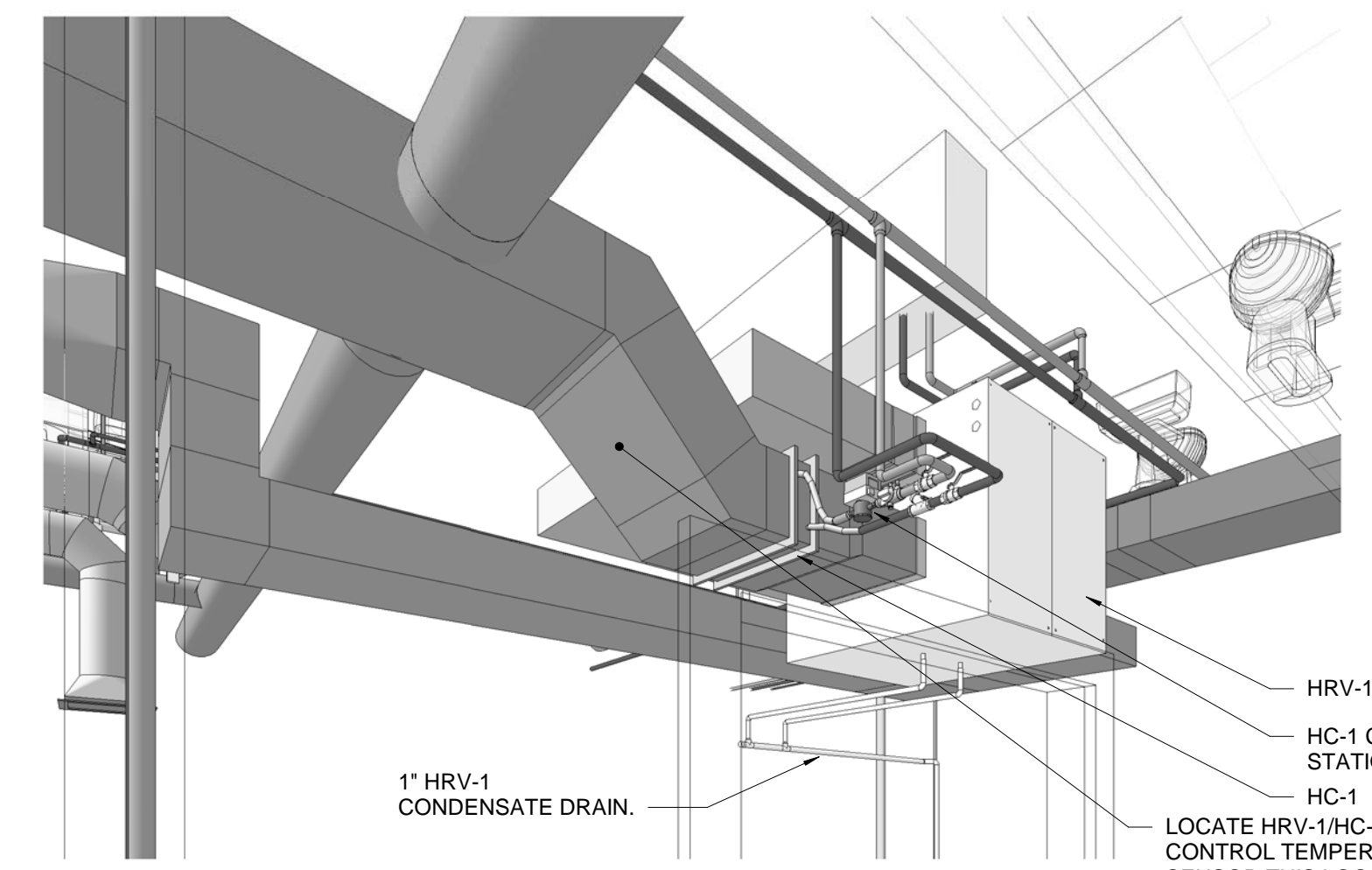

**3 3D VIEW - HRV-1 SYSTEM (VIEW 1)**  
 Not to Scale

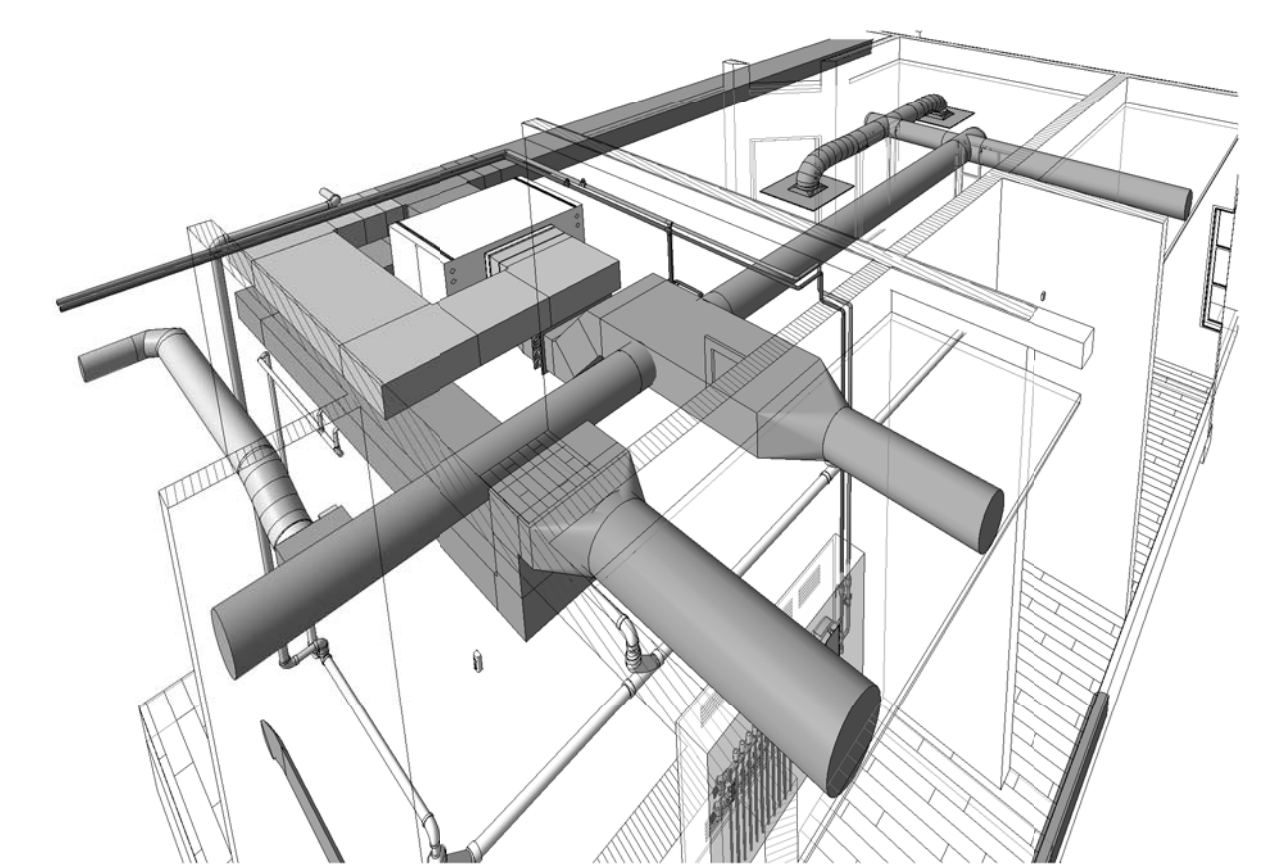

**4 3D VIEW - HRV-1 SYSTEM (VIEW 2)**  
 Not to Scale



REV NO: XX DATE

**ingroup** Engineers, Inc.  
 10000 Chena Road, Suite 200, Anchorage, Alaska 99515  
 (907) 562-1111  
**SAJJ ARCHITECTURE, LLC**  
 SCOTT A. JONES 6375 KULIS DRIVE, ANCHORAGE, ALASKA 99502  
 #907-440-6606 #907-258-6606 (FAX)

**OUZINKIE OFFICE**  
 OUZINKIE NATIVE CORP

JTC  
 DR: JTC/TLT  
 CK: DT: JB: OUZINKIE  
 DWG: MECHANICAL AREA PLANS(V)  
 VIEWS

**M5.4**

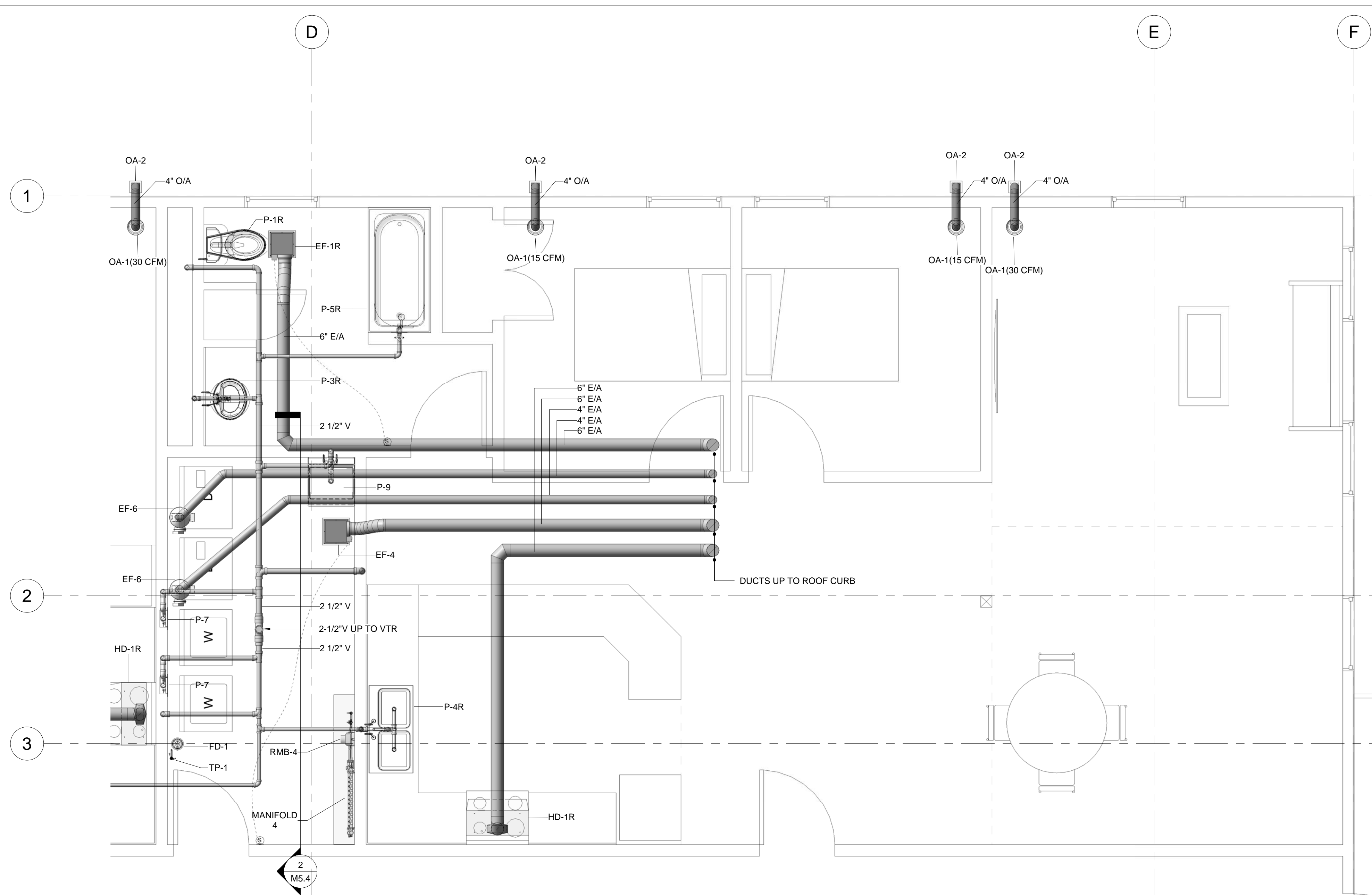

**1 MECHANICAL AREA PLAN - TYPICAL RESIDENT UNIT/LAUNDRY ROOM**  
 Scale: 3/8" = 1'-0"

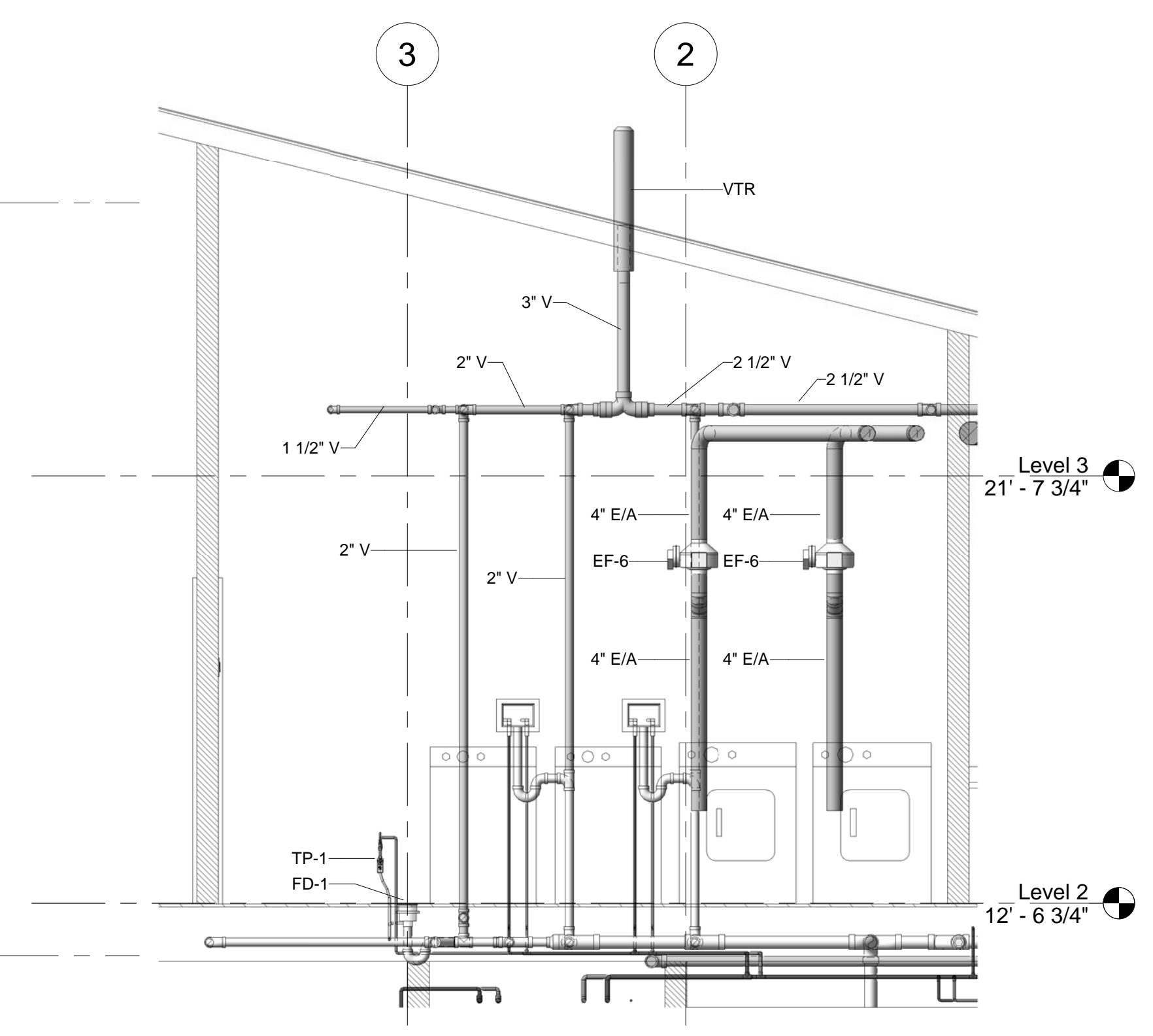

**2 MECH SECTION - LAUNDRY ROOM**  
 Scale: 3/8" = 1'-0"

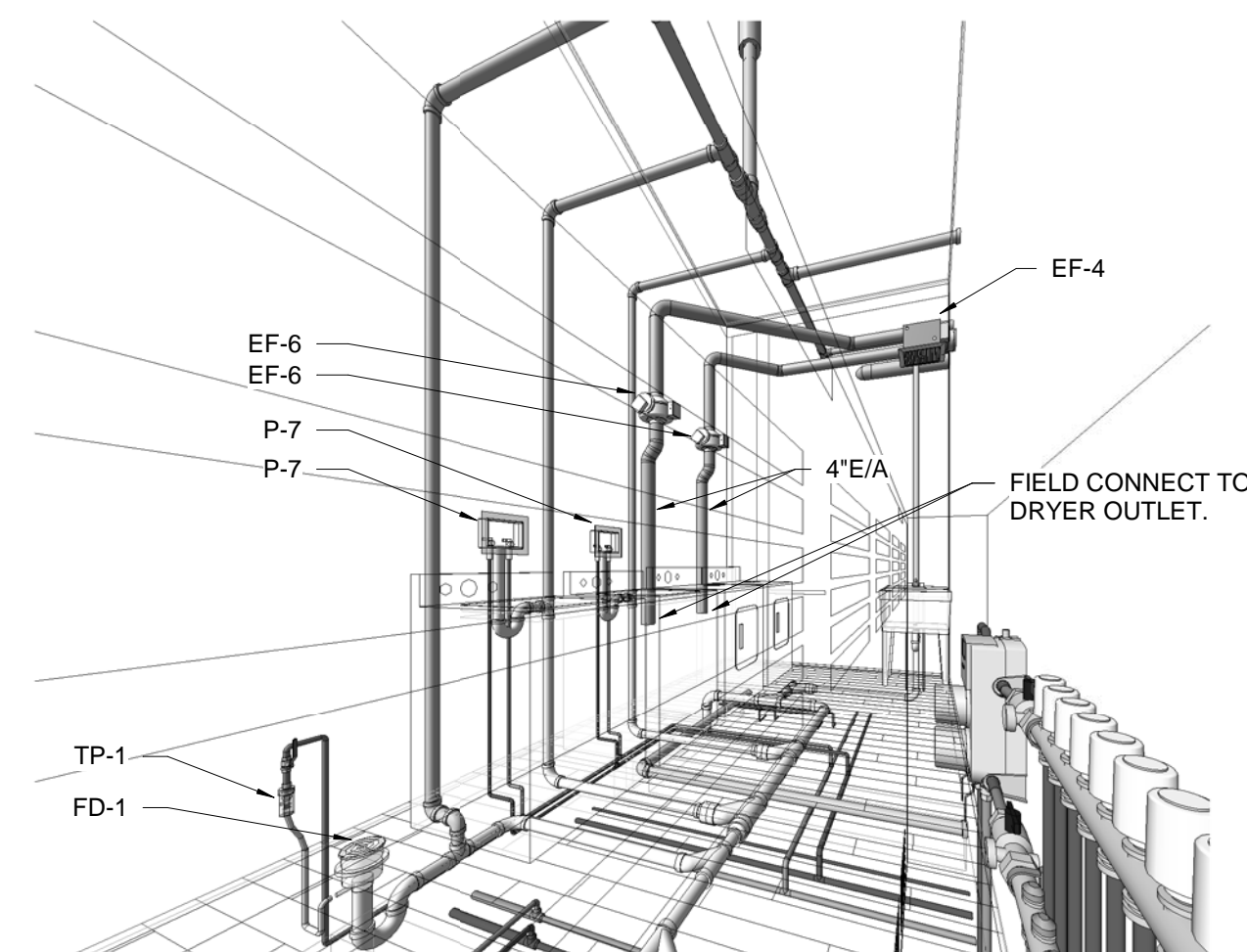

**3 3D VIEW - LAUNDRY ROOM**  
 Not to Scale

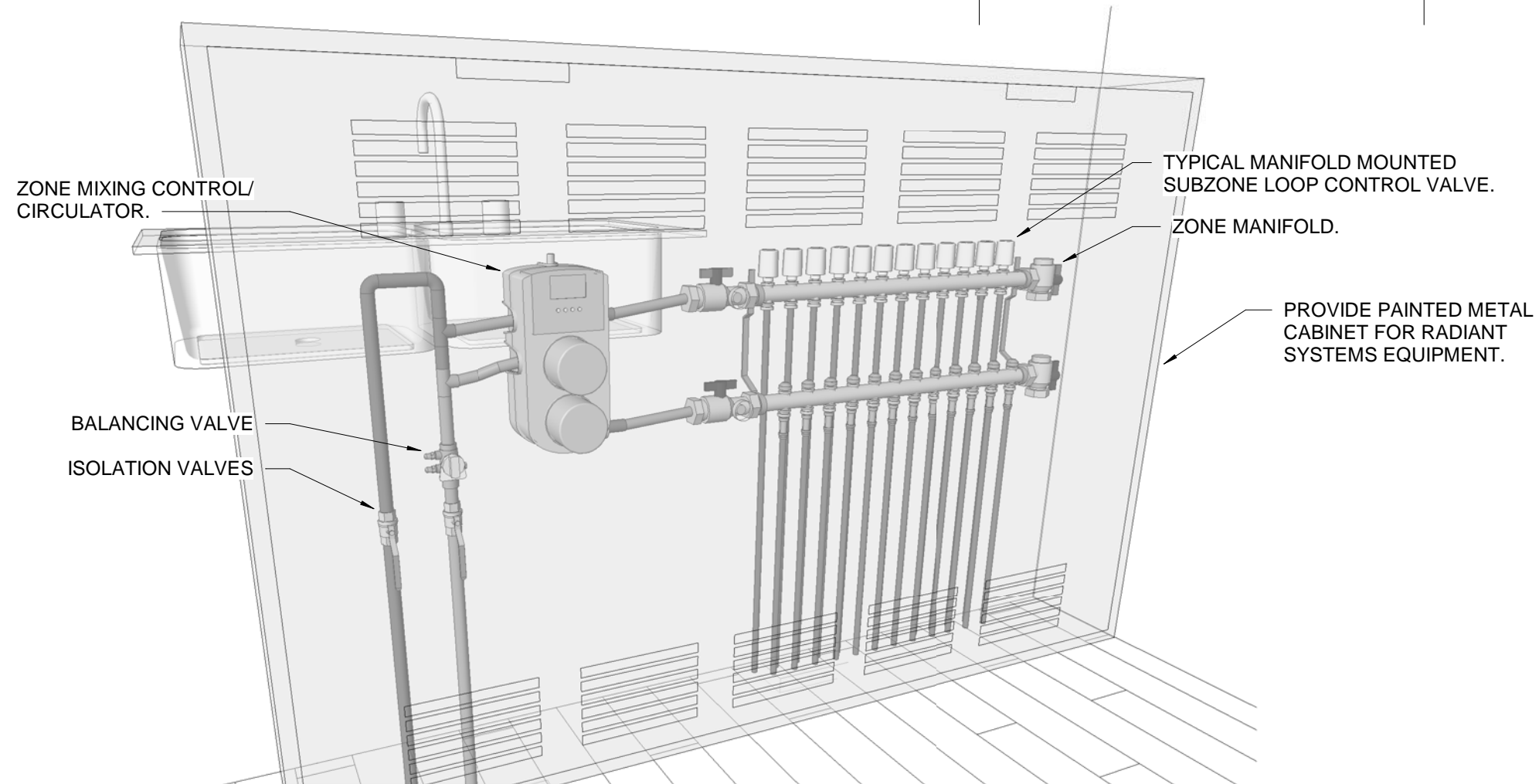

**4 TYP. RADIANT MIXING BLOCK/MANIFOLD**  
 Not to Scale

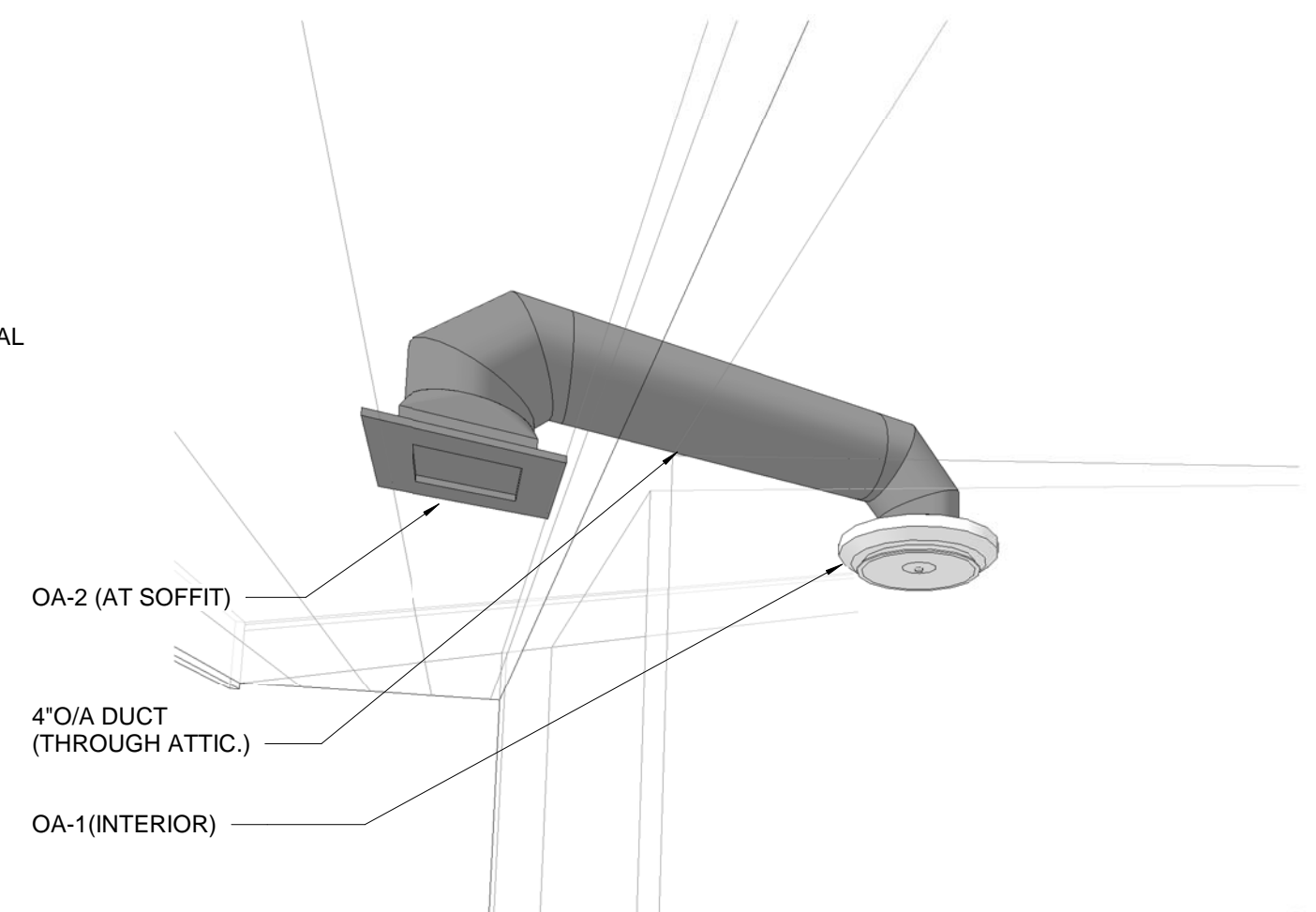

**5 TYP. RESIDENCE OUTSIDE AIR INTAKE**  
 Not to Scale

"IIX17 DRAWINGS ARE HALF THE INDICATED SCALE"

\* 31 OCTOBER 2017 \* BID SET \*